

Kaufmann & Winter

Holzbearbeitungstechnik GmbH
Carl-Eschebach-Straße 1

01454 Radeberg



Telefon: 03528 - 445 924

E-Mail: info@kaufmann-winter.de

Fax: 03528 - 445 925

Internet: www.kaufmann-winter.de

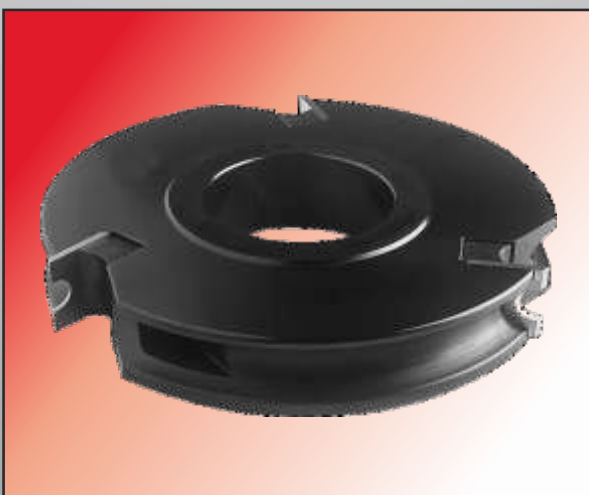

207

FASEFRÄSER Z4
BEVEL CUTTER T4



ØD X B X Ød	Stahl-qualität	Z	Bestell-Nr. Part-No.
ØD X W X Ød	Quality	T	
175 X 50 X 30 mm	HW/T.C.	4	207.8.175.050

Anwendungsbeispiele:
Examples of application:

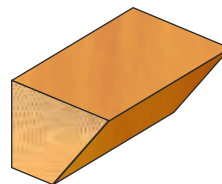

Ausführung:

Stahlkörper mit HW-Wechselplatten
n 4300 – 7400

Anwendung:

45° - Fasen in Holz- bzw Holzwerkstoffen

Technical details:

Tool body in steel with reversible knives.
n 4300 – 7400

Application:

Bevels of 45° in wood, plywood, chipboard etc.

1605

FASEFRÄSER Z4
BEVEL CUTTER T4

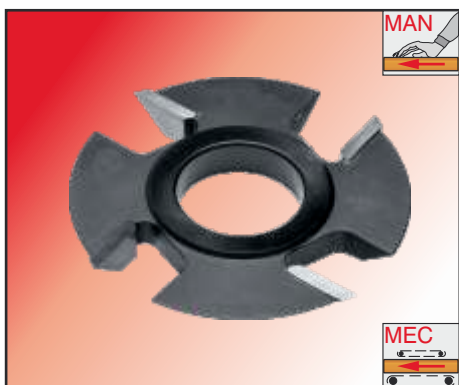

ØD X B X Ød	Stahl-qualität	Z	Bestell-Nr. Part-No.
ØD X W X Ød	Quality	T	
140 X 15 X 30 mm	HW/T.C.	4	1605.4.140.015
150 X 30 X 30 mm	HW/T.C.	4	1605.4.150.030

Anwendungsbeispiele:
Examples of application:

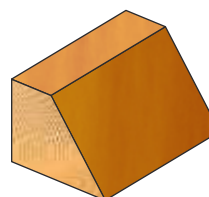

Ausführung:

HW-bestückt, 4 Schneiden, Umfang- und am kleinen Durchmesser auch flankenschneidend
D 140 n 5500 - 9500
D 150 n 5200 - 8900

Anwendung:

45° - Fasen in Holz- bzw Holzwerkstoffen

Technical details:

4 wings, periphery and on small diameter cutting
D 140 n 5500 - 9500
D 150 n 5200 - 8900

Application:

Bevels of 45° in wood, plywood, chipboard etc

1691

WECHSELPLATTEN-HALBSTABFRÄSER Z3 CONCAVE CUTTERHEAD - INTERCHANGEABLE TIPS T3



Ausführung:

Grundkörper aus hochwertigem Stahl,
3 achsparallele Schneiden, nur
umfangschneidend,
geräuscharme Ausführung.
n: 5000 - 9500

Anwendung:

Zum Abrunden von Hölzern und Platten aller Art.

Technical details:

Tool body of steel,
3 straight teeth, only cutting on periphery,
noise reducing shape.
R.P.M.: 5000 - 9500

Application:

For rounding wood and panel materials.

ØD X B X Ød	Stahl- qualität	Z	Radius	Bestell-Nr. Part-No.
ØD X W X Ød	Quality	T	Radius	
140 X 20 X 30mm	HW/T.C.	3	R5 (4/5/6)	1691.11
140 X 30 X 30mm	HW/T.C.	3	R10 (8/10)	1691.12

Ersatzmesser HW	Radius	VE	Bestell-Nr.
Spare knives T.C.	Radius	PU	Part-No.
20 mm	R4	2	1691.2004
20 mm	R5	2	1691.2005
20 mm	R6	2	1691.2006
30 mm	R8	2	1691.3008
30 mm	R10	2	1691.3010

VE = Verpackungseinheit
PU = Packing unit

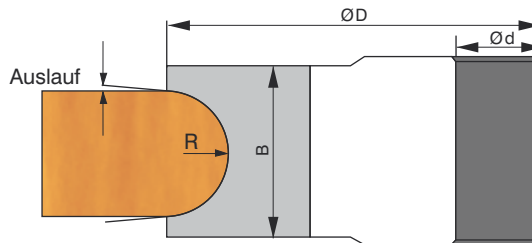

218

WECHSELPLATTEN-RADIENFRÄSER Z3 RADIUS CUTTER - INTERCHANGEABLE TIPS T3



Ausführung:

Tragekörper aus hochfestem Stahl,
3 HW-Wechselschneidplatten.
n:5500-9500

Anwendung:

Abrunden (Viertelstab) und Halbhohlkehlen an Massiv-
hölzern und Plattenwerkstoffen.

Technical details:

Tool body of high solid steel.
3 interchangeable T.C.-tips.
R.P.M.: 5500-9500

Application:

For rounding (quarter round) and convex quarter
round on solid wood and panel materials.

ØD X B X Ød	Stahl- qualität	Z	Radius	Bestell-Nr. Part-No.
ØD X W X Ød	Quality	T	Radius	
140 X 20 X 30mm	HW/T.C.	3	R5 (5/6/7)	218.8.140.005
140 X 25 X 30mm	HW/T.C.	3	R10 (8/10)	218.8.140.010
140 X 35 X 30mm	HW/T.C.	3	R12 (12/15)	218.8.140.012

Ersatzmesser HW	VE	Bestell-Nr.
Spare knives T.C.	PU	Part-No.
Wechselplatte für/Interchangeable tips for R5	3	218.005
Wechselplatte für/Interchangeable tips for R6	3	218.006
Wechselplatte für/Interchangeable tips for R7	3	218.007
Wechselplatte für/Interchangeable tips for R8	3	218.008
Wechselplatte für/Interchangeable tips for R10	3	218.010
Wechselplatte für/Interchangeable tips for R12	3	218.012
Wechselplatte für/Interchangeable tips for R15	3	218.015

VE = Verpackungseinheit
PU = Packing unit

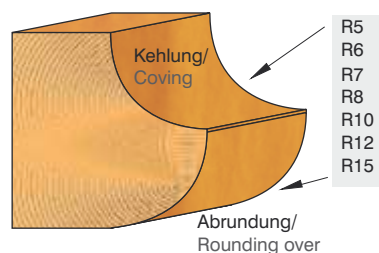

219

WECHSELPLATTEN-ABRUNDDRÄSER Z3 RADIUS CUTTER - INTERCHANGEABLE TIPS T3

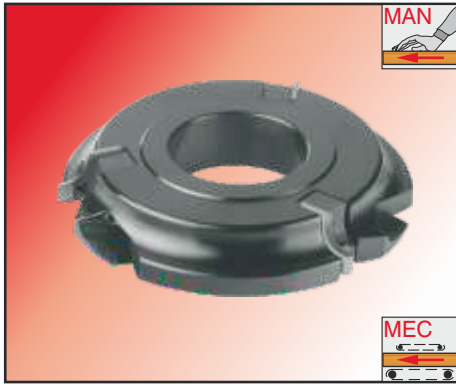

ØD X B X Ød ØD X W X Ød	Stahl- qualität Quality	Z T	Radius Radius	Bestell-Nr. Part-No.
125,5 X 20 X 30mm	HW/T.C.	3	R5 (7)	219.01
132,5 X 20 X 30mm	HW/T.C.	3	R8 (10)	219.02
141 X 25 X 30mm	HW/T.C.	3	R12 (15)	219.03

Ersatzmesser HW Spare knives T.C.	VE PU	Bestell-Nr. Part-No.
Wechselplatte für/Interchangeable tips for R5	3	219.11
Wechselplatte für/Interchangeable tips for R7	3	219.12
Wechselplatte für/Interchangeable tips for R8	3	219.13
Wechselplatte für/Interchangeable tips for R10	3	219.14
Wechselplatte für/Interchangeable tips for R12	3	219.15
Wechselplatte für/Interchangeable tips for R15	3	219.16

VE = Verpackungseinheit
PU = Packing unit

Ausführung:

Tragekörper aus hochfestem Stahl,
3 HW-Wechselschneidplatten.
Ø125,5 n: 6100-10500
Ø132,5 n: 5800-10000
Ø141 n: 5400-9400

Anwendung:

Abrunden (Viertelstab) Massiv-
hölzern und Plattenwerkstoffen.

Technical details:

Tool body of high solid steel.
3 interchangeable T.C.-tips.
Ø125,5 RPM: 6100-10500
Ø132,5 RPM: 5800-10000
Ø141 RPM: 5400-9400

Application:

For rounding (quarter round)
on solid wood and panel materials.

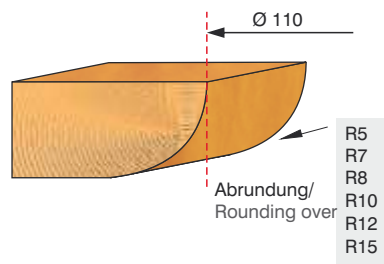

289

HOHLKEHLFRAESER Z4 CONCAVE CUTTER T4



ØD X B X Ød ØD X W X Ød	Stahl- qualität Quality	Z T	Radius Radius	Bestell-Nr. Part-No.
140 X 5 X 30mm	HW/T.C.	4	R2,5	289.50
140 X 6 X 30mm	HW/T.C.	4	R3	289.51
140 X 8 X 30mm	HW/T.C.	4	R4	289.52
140 X 10 X 30mm	HW/T.C.	4	R5	289.53
140 X 12 X 30mm	HW/T.C.	4	R6	289.54
140 X 15 X 30mm	HW/T.C.	4	R7,5	289.55
140 X 20 X 30mm	HW/T.C.	4	R10	289.56
140 X 40 X 30mm	HW/T.C.	4	R20	289.57

Ausführung:

Stahlkörper R2,5-20
4 HW-Schneiden
n: 5500-9500

Anwendung:

Zur Herstellung von Hohlkehlen oder Halbhohlkehlen
in Massivholz und Plattenwerkstoffen (MDF).

Technical details:

Body of heigt class steel, R2,5-20
4 cutting Knives
RPM: 5500-9500

Application:

For profiling gorges in solid wood and panel
materials (MDF).

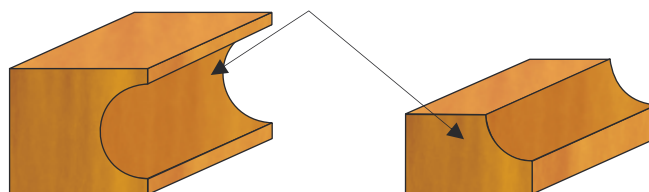

1690

WENDEPLATTEN-ABRUND-FÜGE-FASE-GARNITUR ROUNDING-JOINTING-BEVELLING CUTTER SET REVERSIBLE TIPS



Ausführung: Grundkörper aus Stahl. Einsatz mit oder ohne Fügebearbeitung, verstellbar durch Zwischenringe.

Garnitur besteht aus je 1 oberen und unteren Radiusfasekopf und Fügekopf. 50 mm Breite, 40 mm Bohrung. Durch den Einsatz von verschiedenen Platten können auch andere Radien und Fase 45° hergestellt werden.

Anwendung:
Für Abrundungen oder Fasen mit oder ohne Fügebearbeitung, in MDF, Spanplatten sowie Hart- und Weichhölzer.

Technical details:

Tool body of steel. Applicable with or without jointing head, adjustable with spacers.
Cutter set consisting of 1 top and 1 bottom radius and 1 jointing cutterhead 50mm width, 40mm bore. By inserting different tips various profiles can be effected.

Application:

For rounding off/bevelling with or without jointing head in MDF, chipboard and solid hard or soft wood.

Garnitur-1-

Garnitur -1- Cutter set -1-	3-teilig 3-part	Bestell-Nr. Part-No.
--------------------------------	--------------------	-------------------------

R=5 (Zusatzmesser extra für R2 / R3 / R4 / R6 /45° lieferbar)

R=5 (Additional knives for R2 / R3 / R4 / R6 /45° available)

-1- R5-Garnitur komplett mit Messer/Ringe 3-tlg. Ø125mm

-1- R5-Cutter set complete with knives/spacers 3-prt. Ø125mm 1690.03

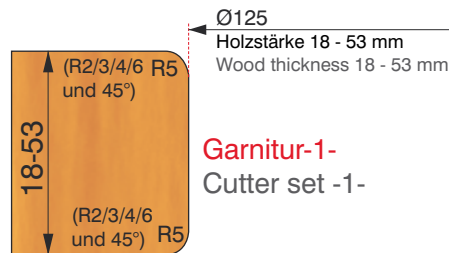

Garnitur-1-
Cutter set -1-

Garnitur-2-

Garnitur -2- Cutter set -2-	3-teilig 3-part	Bestell-Nr. Part-No.
--------------------------------	--------------------	-------------------------

R=10 (Zusatzmesser extra für R6 / R7 / R8 / 45° lieferbar)

R=10 (Additional knives for R6 / R7 / R8 / 45° available)

-2- R10-Garnitur komplett mit Messer/Ringe 3-tlg. Ø125mm

-2- R10-Cutter set complete with knives/spacers 3-prt. Ø125mm 1690.04

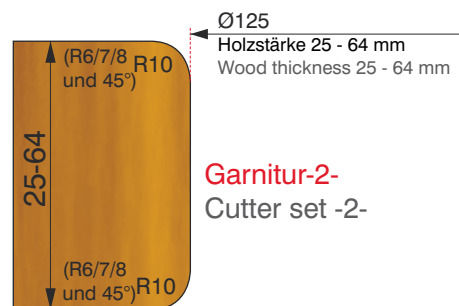

Garnitur-2-
Cutter set -2-

Ersatzmesser HW T.C. spare tips	VE PU	Bestell-Nr. Part-No.
30X12X1,5mm Wendeplatte/Reversible tip	10	301215
50X12X1,5mm Wendeplatte/Reversible tip	10	501215
R2 Wechselplatte /Interchangeable tip	3	1690.11
R3 Wechselplatte /Interchangeable tip	3	1690.12
R4 Wechselplatte /Interchangeable tip	3	1690.13
R5 Wechselplatte /Interchangeable tip	3	1690.14
R6 Wechselplatte /Interchangeable tip	3	1690.15
R8 Wechselplatte /Interchangeable tip	3	1690.17
R10 Wechselplatte /Interchangeable tip	3	1690.18
45°(Ø125) Wechselplatte /Interchangeable tip	3	1690.22

VE = Verpackungseinheit
PU = Packing unit



Ausführung:

Grundkörper aus hochwertigem Stahl
2/4 achsparallele Messeraufnahmen, Hochgenauigkeitsverzahnung an der Spannfläche, die Zahnteilung dient zugleich zur gleichmäßigen Einstellung der Messer im Flugkreis, durch Einsatz von 2 Ausgleichstücken kann mit 2 statt mit 4 Messern gearbeitet werden, hierbei sind gegenüberliegend 2 Ausgleichstücke einzusetzen.
n: ØD=122mm: 9000 ØD=137mm: 8000

Anwendung:

Profilieren von Massivholz, auf Maschinen mit MECH.VORSCHUB (MEC) bei hoher Spindel-drehzahl und hoher Vorschubgeschwindigkeit.

Technical details:

Tool body of high class steel, with 4 straight teeth having precision ground serrations on back. The serration is for setting the knives in constant diameter. When using 2 filling pieces it is possible to work with 2 instead of 4 knives. The filling pieces have to be mounted oppositely.
R.P.M.: ØD=122mm: 9000 ØD=137mm: 8000

Application:

Profiling solid wood on machines with mechanical feed at high R.P.M. Best surface quality at high speed.



Tabelle zur Bestimmung der max. Profiltiefe in Abhängigkeit von der Messerhöhe:

Kopf-Ø Cutter- head Ø	Messer- höhe Height of knives	Max. Profil- tiefe Max. profile depth	Flugkreis Ø Cutting Ø
122	50	15	160
122	60	22	180
122	70	30	200
137	50	15	175
137	60	22	195
137	70	30	215

Messerkopf mit Spannkeilen ohne Messer / Cutterhead with clamping wedges, without knives

ØD X B X Ød ØD X W X Ød	Z T	Bestell-Nr. Part-No.
122 X 40 X 40 mm	2	252.122240
122 X 60 X 40 mm	2	252.122260
122 X 80 X 40 mm	2	252.122280
122 X 40 X 40 mm	4	252.122040
122 X 60 X 40 mm	4	252.122060
122 X 80 X 40 mm	4	252.122080
122 X 100 X 40 mm	4	252.122100
122 X 130 X 40 mm	4	252.122130
122 X 150 X 40 mm	4	252.122150
122 X 180 X 40 mm	4	252.122180
122 X 230 X 40 mm	4	252.122230
137 X 60 X 50 mm	4	252.137060
137 X 100 X 50 mm	4	252.137100
137 X 130 X 50 mm	4	252.137130
137 X 150 X 50 mm	4	252.137150
137 X 180 X 50 mm	4	252.137180

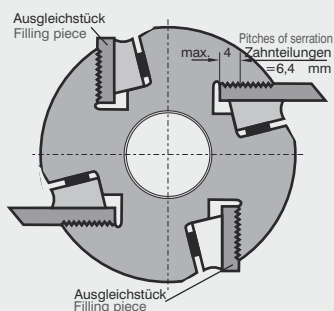
Auch in Hydro-Ausführung lieferbar.

Also available in execution hydro.

HS-Blanketts / HSS - Blank knives

B X H X S W X H X S	Stahl- qualität Quality	Bestell-Nr. Part-No.
40 X 50 X 8 mm	HS-massiv/Solid HSS	252.040500
60 X 50 X 8 mm	HS-massiv/Solid HSS	252.060500
80 X 50 X 8 mm	HS-massiv/Solid HSS	252.080500
100 X 50 X 8 mm	HS-massiv/Solid HSS	252.100500
130 X 50 X 8 mm	HS-massiv/Solid HSS	252.130500
150 X 50 X 8 mm	HS-massiv/Solid HSS	252.150500
180 X 50 X 8 mm	HS-massiv/Solid HSS	252.180500
230 X 50 X 8 mm	HS-massiv/Solid HSS	252.230500
40 X 60 X 8 mm	HS-massiv/Solid HSS	252.040600
60 X 60 X 8 mm	HS-massiv/Solid HSS	252.060600
80 X 60 X 8 mm	HS-massiv/Solid HSS	252.080600
100 X 60 X 8 mm	HS-massiv/Solid HSS	252.100600
130 X 60 X 8 mm	HS-massiv/Solid HSS	252.130600
150 X 60 X 8 mm	HS-massiv/Solid HSS	252.150600
180 X 60 X 8 mm	HS-massiv/Solid HSS	252.180600
230 X 60 X 8 mm	HS-massiv/Solid HSS	252.230600
40 X 70 X 8 mm	HS-massiv/Solid HSS	252.040700
60 X 70 X 8 mm	HS-massiv/Solid HSS	252.060700
80 X 70 X 8 mm	HS-massiv/Solid HSS	252.080700
100 X 70 X 8 mm	HS-massiv/Solid HSS	252.100700
130 X 70 X 8 mm	HS-massiv/Solid HSS	252.130700
150 X 70 X 8 mm	HS-massiv/Solid HSS	252.150700
180 X 70 X 8 mm	HS-massiv/Solid HSS	252.180700
230 X 70 X 8 mm	HS-massiv/Solid HSS	252.230700

Ausgleichstücke / Filling pieces

B W	Bestell-Nr. Part-No.
40 mm	252.0404
60 mm	252.0604
80 mm	252.0804
100 mm	252.1004
130 mm	252.1304
150 mm	252.1504
180 mm	252.1804
230 mm	252.2304

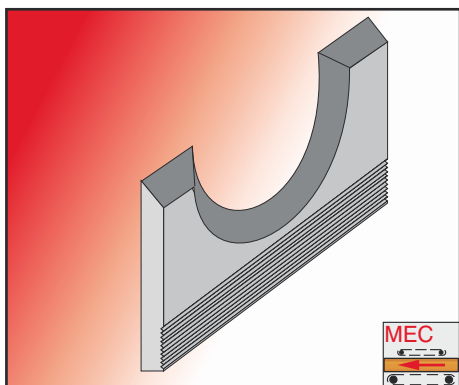

Ausführung:

Profilmesser je nach Schwierigkeit des Profils Gruppe -1- bzw. -2- bzw. -3- HS-massiv 8mm stark mit Rückenverzahnung passgenau geschliffen zu Profilmesserkopf 252 passend.

Anwendung:

Zum Profilieren von Massivholz auf Maschinen mit MECH.VORSCHUB (MEC) bei hoher Spindeldrehzahl und hoher Vorschubgeschwindigkeit.

Technical details:

Profile knives are split up in three profile groups -1-, -2- and -3- depending on difficulty of profile, solid-HSS 8mm thick having precision ground serrations on back for profile cutterhead no. 252.

Application:

Profiling solid wood on machines with mechanical feed at high R.P.M. Best surface quality at high feed speed.

Beispiele Profilgruppe/Example profile group -1-

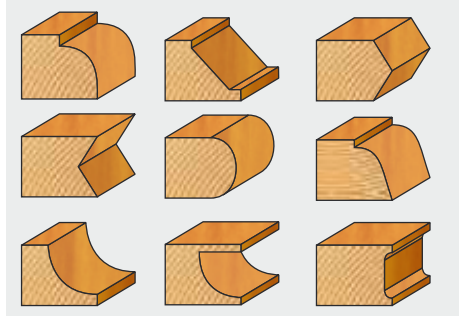

Beispiele Profilgruppe/Example profile group -2-

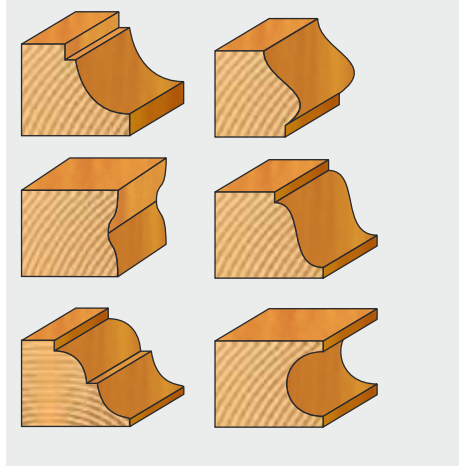

Profilmesser Profilgruppe -1- / Profile knives profile group -1-

B X H X S W X H X S	Stahlqualität Quality	max. Profiltiefe Profile depth	Bestell-Nr. Part-No.
40 X 50 X 8 mm	HS-massiv/Solid HSS	15 mm	252.040501
60 X 50 X 8 mm	HS-massiv/Solid HSS	15 mm	252.060501
80 X 50 X 8 mm	HS-massiv/Solid HSS	15 mm	252.080501
100 X 50 X 8 mm	HS-massiv/Solid HSS	15 mm	252.100501
130 X 50 X 8 mm	HS-massiv/Solid HSS	15 mm	252.130501
150 X 50 X 8 mm	HS-massiv/Solid HSS	15 mm	252.150501
180 X 50 X 8 mm	HS-massiv/Solid HSS	15 mm	252.180501
230 X 50 X 8 mm	HS-massiv/Solid HSS	15 mm	252.230501
40 X 60 X 8 mm	HS-massiv/Solid HSS	22 mm	252.040601
60 X 60 X 8 mm	HS-massiv/Solid HSS	22 mm	252.060601
80 X 60 X 8 mm	HS-massiv/Solid HSS	22 mm	252.080601
100 X 60 X 8 mm	HS-massiv/Solid HSS	22 mm	252.100601
130 X 60 X 8 mm	HS-massiv/Solid HSS	22 mm	252.130601
150 X 60 X 8 mm	HS-massiv/Solid HSS	22 mm	252.150601
180 X 60 X 8 mm	HS-massiv/Solid HSS	22 mm	252.180601
230 X 60 X 8 mm	HS-massiv/Solid HSS	22 mm	252.230601
40 X 70 X 8 mm	HS-massiv/Solid HSS	30 mm	252.040701
60 X 70 X 8 mm	HS-massiv/Solid HSS	30 mm	252.060701
80 X 70 X 8 mm	HS-massiv/Solid HSS	30 mm	252.080701
100 X 70 X 8 mm	HS-massiv/Solid HSS	30 mm	252.100701
130 X 70 X 8 mm	HS-massiv/Solid HSS	30 mm	252.130701
150 X 70 X 8 mm	HS-massiv/Solid HSS	30 mm	252.150701
180 X 70 X 8 mm	HS-massiv/Solid HSS	30 mm	252.180701
230 X 70 X 8 mm	HS-massiv/Solid HSS	30 mm	252.230701

Profilmesser Profilgruppe -2- / Profile knives profile group -2-

Mehrpreis / Additional costs Bestell-Nr. Part-No. 252.02

Profilmesser Profilgruppe -3- / Profile knives profile group -3-

Mehrpreis / Additional costs Bestell-Nr. Part-No. 252.03

Bitte unbedingt beachten:

Sofern nicht bereits vorhanden, wird zu jedem Profilmesser eine Schleifschablone benötigt. Die max. Verstellung von nachgeschliffenen Messern beträgt 4-Zahnteilungen = 6,4 mm.

Please note:

Unless already existing, for each profile knife a template is necessary. Max. adjustment of knives after regrinding 4 pitches of serration = 6,4mm.

Schleifschablone / Templates

Messerbreite Cutting width	Profilgruppe Profile group	Bestell-Nr. Part-No.
40 mm	1	252.0401
60 mm	1	252.0601
80 mm	1	252.0801
100 mm	1	252.1001
130 mm	1	252.1301
150 mm	1	252.1501
180 mm	1	252.1801
230 mm	1	252.2301
Mehrpreis / Additional costs 2		252.502
Mehrpreis / Additional costs 3		252.503

Beispiele Profilgruppe/Example profile group -3-

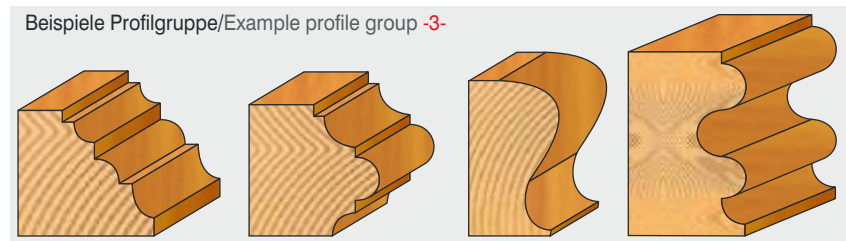

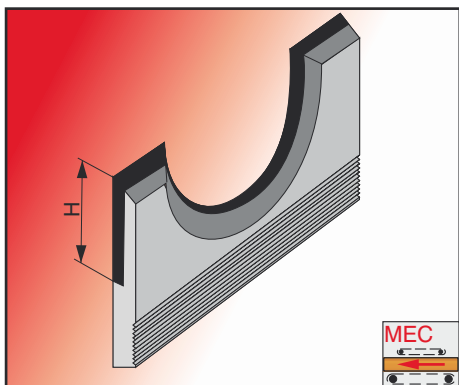

Ausführung:

Profilmesser je nach Schwierigkeit des Profils Gruppe -1- bzw. -2- bzw. -3- HS-massiv 10mm stark mit Rückenverzahnung passgenau geschliffen zu Profilmesserkopf 252 passend.

Anwendung:

Zum Profilieren von Massivholz auf Maschinen mit MECH.VORSCHUB (MEC) bei hoher Spindeldrehzahl und hoher Vorschubgeschwindigkeit.

Technical details:

Profile knives are split up in three profile groups -1-, -2- and -3- depending on difficulty of profile, solid-HSS 10mm thick having precision ground serrations on back for profile cutterhead no. 252.

Application:

Profiling solid wood on machines with mechanical feed at high R.P.M. Best surface quality at high feed speed.

Beispiele Profilgruppe/Example profile group -1-

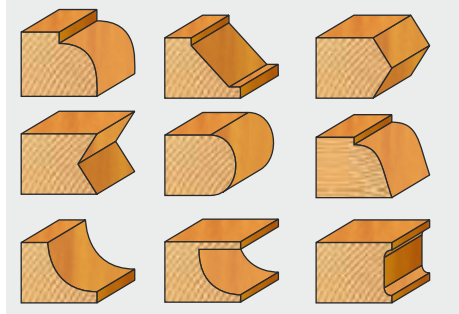

Beispiele Profilgruppe/Example profile group -2-

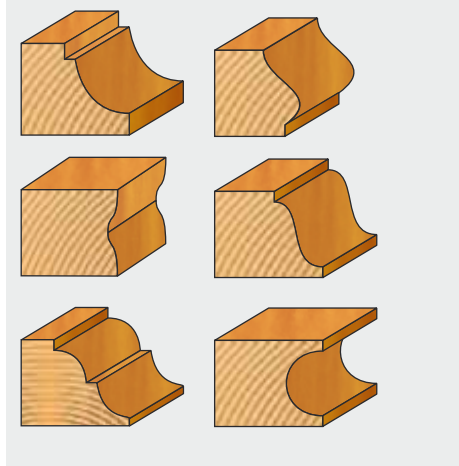

Profilmesser Profilgruppe -1- / Profile knives profile group -1-

B X H X S W X H X S	Stahlqualität Quality	H H	Bestell-Nr. Part-No.
40 X 50 X 10 mm	HW/T.C.	20 mm	252.040502
60 X 50 X 10 mm	HW/T.C.	20 mm	252.060502
80 X 50 X 10 mm	HW/T.C.	20 mm	252.080502
100 X 50 X 10 mm	HW/T.C.	20 mm	252.100502
130 X 50 X 10 mm	HW/T.C.	20 mm	252.130502
150 X 50 X 10 mm	HW/T.C.	20 mm	252.150502
180 X 50 X 10 mm	HW/T.C.	20 mm	252.180502
230 X 50 X 10 mm	HW/T.C.	20 mm	252.230502
40 X 60 X 10 mm	HW/T.C.	25 mm	252.040602
60 X 60 X 10 mm	HW/T.C.	25 mm	252.060602
80 X 60 X 10 mm	HW/T.C.	25 mm	252.080602
100 X 60 X 10 mm	HW/T.C.	25 mm	252.100602
130 X 60 X 10 mm	HW/T.C.	25 mm	252.130602
150 X 60 X 10 mm	HW/T.C.	25 mm	252.150602
180 X 60 X 10 mm	HW/T.C.	25 mm	252.180602
230 X 60 X 10 mm	HW/T.C.	25 mm	252.230602
40 X 70 X 10 mm	HW/T.C.	30 mm	252.040702
60 X 70 X 10 mm	HW/T.C.	30 mm	252.060702
80 X 70 X 10 mm	HW/T.C.	30 mm	252.080702
100 X 70 X 10 mm	HW/T.C.	30 mm	252.100702
130 X 70 X 10 mm	HW/T.C.	30 mm	252.130702
150 X 70 X 10 mm	HW/T.C.	30 mm	252.150702
180 X 70 X 10 mm	HW/T.C.	30 mm	252.180702
230 X 70 X 10 mm	HW/T.C.	30 mm	252.230702

Profilmesser Profilgruppe -2- / Profile knives profile group -2-

Mehrpreis / Additional costs	Bestell-Nr. Part-No.
	252.02

Profilmesser Profilgruppe -3- / Profile knives profile group -3-

Mehrpreis / Additional costs	Bestell-Nr. Part-No.
	252.03

Bitte unbedingt beachten:

Sofern nicht bereits vorhanden, wird zu jedem Profilmesser eine Schleifschablone benötigt. Die max. Verstellung von nachgeschliffenen Messern beträgt 4-Zahnteilungen = 6,4 mm.

Please note:

Unless already existing, for each profile knife a template is necessary. Max. adjustment of knives after regrinding 4 pitches of serration = 6,4 mm.

Schleifschablone / Templates

Messerbreite Cutting width	Profilgruppe Profile group	Bestell-Nr. Part-No.
40 mm	1	252.0401
60 mm	1	252.0601
80 mm	1	252.0801
100 mm	1	252.1001
130 mm	1	252.1301
150 mm	1	252.1501
180 mm	1	252.1801
230 mm	1	252.2301
Mehrpreis / Additional costs		2
		252.502
Mehrpreis / Additional costs		3
		252.503

Beispiele Profilgruppe/Example profile group -3-

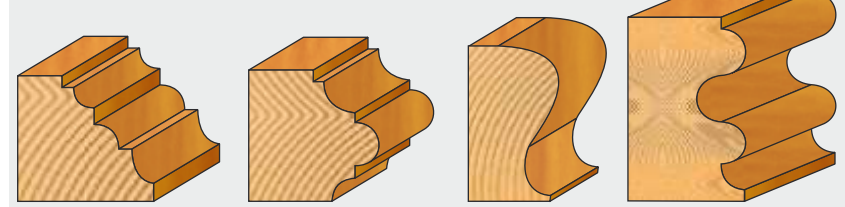

Ausführung:

Profilmesser HW-massiv 3,2mm stark, mit Microverzahnung passgenau geschliffen zu Profilmesserkopf 256 und 252 passend.

Anwendung:

Zum Profilieren von MDF und Spanplatten sowie Massivholz (Weich- und Hartholz) auf Maschinen mit MECH.VORSCHUB (MEC) bei hoher Spindeldrehzahl und hoher Vorschubgeschwindigkeit.

Technical details:

Profile knives - solid-T.C. 3,2mm thickness having high precision ground serrations on back for

Application: Profiling MDF and Chipboard as well as for solid wood (hard- and softwood) on machines with mechanical feed at high R.P.M. Best surface quality at high feed speed.

HW-Profilmesser mit Microverzahnung / Stützplatten
Micro serrated T.C.-profile knives / support plates

B X H X S W X H X S	Stahl- qualität Quality	max. Profiltiefe Profile depth	MDF and Chipboard Part-No.	Hart- u. Weichholz Hard- and Softwood Bestell-Nr. Part-No.
60 X 50 X 3,2mm	HW/ T.C.	12 mm	256.060501	256.060502
80 X 50 X 3,2mm	HW/ T.C.	12 mm	256.080501	256.080502
130 X 50 X 3,2mm	HW/ T.C.	12 mm	256.130501	256.130502
180 X 50 X 3,2mm	HW/ T.C.	12 mm	256.180501	256.180502
60 X 60 X 3,2mm	HW/ T.C.	23 mm	256.060601	256.060602
80 X 60 X 3,2mm	HW/ T.C.	23 mm	256.080601	256.080602
130 X 60 X 3,2mm	HW/ T.C.	23 mm	256.130601	256.130602
180 X 60 X 3,2mm	HW/ T.C.	23 mm	256.180601	256.180602
60 X 47 X 7,1mm	Stützplatte / Support plate	12 mm	256.060471	256.060471
80 X 47 X 7,1mm	Stützplatte / Support plate	12 mm	256.080471	256.080471
130 X 47 X 7,1mm	Stützplatte / Support plate	12 mm	256.130471	256.130471
180 X 47 X 7,1mm	Stützplatte / Support plate	12 mm	256.180471	256.180471
60 X 57 X 7,1mm	Stützplatte / Support plate	23 mm	256.060571	256.060571
80 X 57 X 7,1mm	Stützplatte / Support plate	23 mm	256.080571	256.080571
130 X 57 X 7,1mm	Stützplatte / Support plate	23 mm	256.130571	256.130571
180 X 57 X 7,1mm	Stützplatte / Support plate	23 mm	256.180571	256.180571

Andere Abmessungen kurzfristig auf Anfrage lieferbar.

Special dimensions available on request, short delivery.

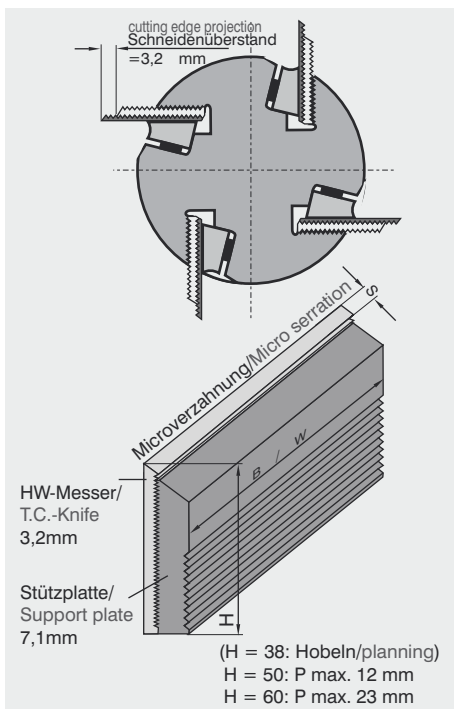

Profilbeispiele siehe vorhergehende Seite.
Profile examples please see previous page.

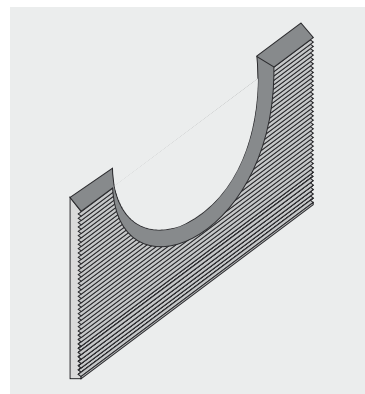
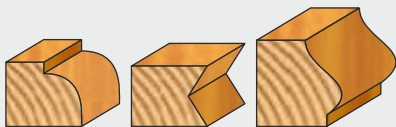

Schleifschablone / Templates

Messerbreite Cutting width	Bestell-Nr. Part-No.
60 mm	256.0601
80 mm	256.0801
130 mm	256.1301
180 mm	256.1801



Ausführung:

Grundkörper aus elastischem Stahl, 2 achsparallele Messer mit Abweiser mit Sondermessern nach Holzmuster bzw. Zeichnung.

n: 6000

Anwendung:

Für verschiedenste Profilierarbeiten.
HSS für Massivhölzer, HW für abrasive Werkstoffe

ØD X B X Ød	Z	Bestell-Nr.
ØD X W X Ød	T	Part-No.
122 X 40 X 30 mm	2	262.122.040
122 X 60 X 30 mm	2	262.122.060
122 X 80 X 30 mm	2	262.122.080
122 X 100 X 30 mm	2	262.122.100

HS-Blanketts / HSS - Blank knives

B X H X S	Stahl-qualität	Bestell-Nr.
W X H X S	Quality	Part-No.
40 X 50 X 8 mm	HS-massiv/Solid HSS	252.040500
60 X 50 X 8 mm	HS-massiv/Solid HSS	252.060500
80 X 50 X 8 mm	HS-massiv/Solid HSS	252.080500
100 X 50 X 8 mm	HS-massiv/Solid HSS	252.100500
40 X 60 X 8 mm	HS-massiv/Solid HSS	252.040600
60 X 60 X 8 mm	HS-massiv/Solid HSS	252.060600
80 X 60 X 8 mm	HS-massiv/Solid HSS	252.080600
100 X 60 X 8 mm	HS-massiv/Solid HSS	252.100600

Technical details:

Tool body of high class steel. 2 axial parallel knives and limitors.
Special profiles according to wood sample or drawing.

R.P.M.: 6000

Application:

For several types of profiling.
HS for wood, TC for abrasive materials.

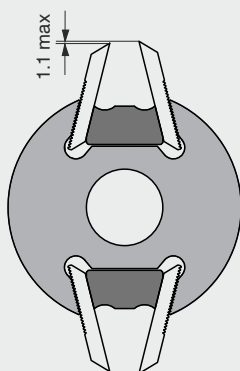

Wechselbacken für / Clamping wedge for Micro-Packsystem

B	Bestell-Nr.
W	Part-No.
40 mm	262.0404
60 mm	262.0604
80 mm	262.0804
100 mm	262.1004

Kopf-Ø Cutter-head Ø	Messer- höhe Height of knives	Max. Profil- tiefe Max. profile depth	Flugkreis Ø Cutting Ø
122	50	15	160
122	60	22	180

Beispiele Profilgruppe/Example profile group

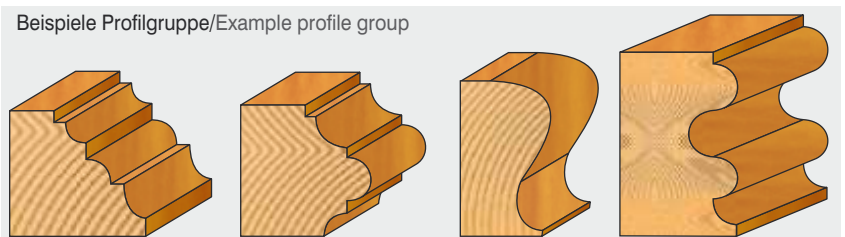

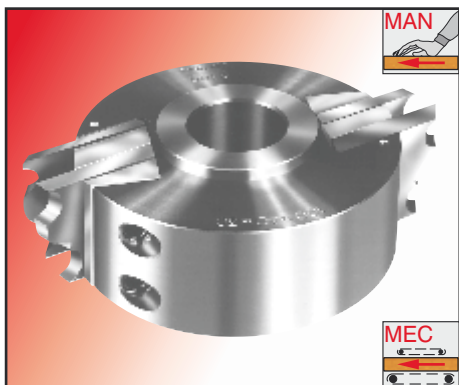

Ausführung:
Grundkörper aus elastischem Stahl, 2 achsparallele Messer mit Abweiser formschlüssige Messerbefestigung. Messer und Abweiser fest zueinander fixiert, Messer mit Abweiser im Flugkreis verstellbar und nach oben und unten schwenkbar. Sicherer und schneller Messerwechsel zum Einsatz mit Standardprofilmessern oder mit Sondermessern nach Holzmuster bzw. Zeichnung.
Max. Schnittbreite bei Sondermessern 44 mm
n: 6000

Anwendung:
Zum Profilieren von Massivholz im Innenausbau, Möbel- und Modellbau.

Technical details:

Tool body of high class steel. 2 axial parallel knives and limitors are one unit.
Knives in conformance with limitors are adjustable in cutting circle diameter and pivot mounted up or down to max 10°. Secure and easy knife change. For standard profile knives or special profiles according to wood sample or drawing.
Max. cutting width on special knives 44mm
Max. profile depth 17mm
R.P.M.: 6000
Knives with limitors are regrindable (both in same rate).

Application:

For profiling in solid wood.
For producing frames e.g. for kitchen, furniture, doors, picture frames and more.

Passende Standard-Messersätze finden Sie auf den Folgeseiten.
Suitable standard knife sets please see the following pages.

Hochleistungsstahl für hohe Standwege, (keine Wegwerfmesser).

HL-steel (high alloyed tool steel) for long working life, no SP-steel (no throw away knives).

Messerkopf mit Spannelementen / Cutterhead with clamping elements

ØD X B X Ød ØD X W X Ød	Bestell-Nr. Part-No.
100 X 40 X 30 mm	250/11.80
120 X 40 X 30 mm	250/11.81
120 X 40 X 40 mm	250/11.82

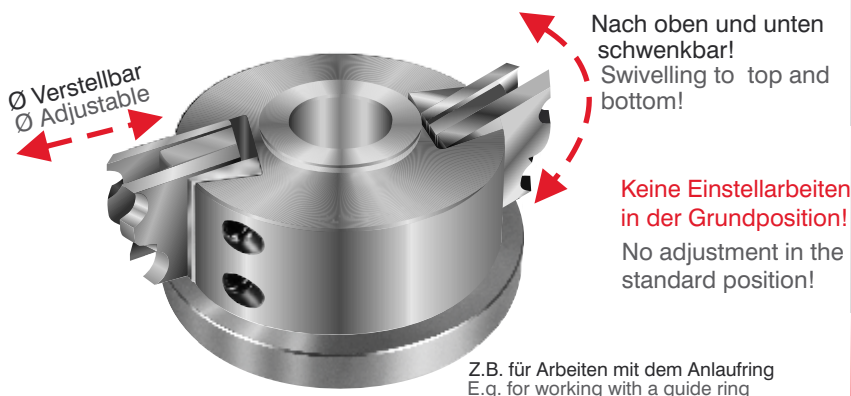

Ersatz- und Zusatzteile Spare- und additional parts	Bestell-Nr. Part-No.
Einstell-Vorrichtung / Setting device	250/11.90
Messersicherungsschraube / Knife saving screw	250/11.87
Spannschraube (alte Ausführung) mit Innensechskant Clamping screw (old type) within hexagon	250/11.88
Spannschraube (neue Ausführung) Torx 30 Clamping screw (new type) Torx 30	250/11.93
Ersatzschlüssel SW5 / Spare key SW5	250/11.89
Torx-Schlüssel T30 / Torx key T30	250/11.92
Schleifschablone -extra-/ Template -extra-	250/11.99

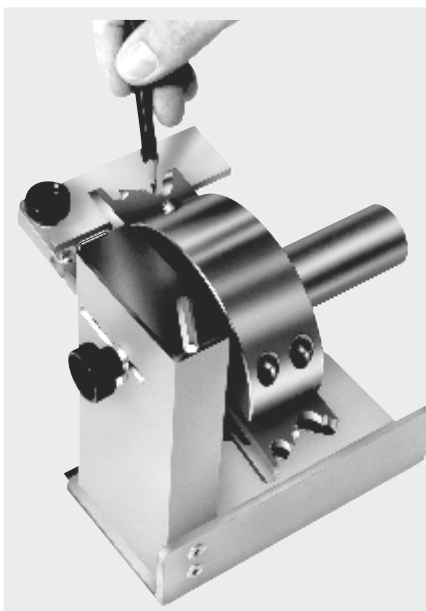

EINSTELL-VORRICHTUNG

Die Einstellvorrichtung dient zum exakten Einstellen beim Schwenken und Flugkreisverändern. Beispiel hierfür ist das Arbeiten mit Anlauftring wobei der Flugkreis des Messerkopfes genau auf den Durchmesser des Anlauftringes eingestellt werden kann. In der Grundposition sind jedoch keine Einstellarbeiten notwendig. Auch sind die Messer und Abweiser fest zueinander fixiert.

SETTING-DEVICE

The setting device is used for the exact adjustment for swivelling and choosing the cutting circle. For example when working with a guide ring the cutting circle of the cutterhead can be adjusted to the diameter of the guide ring. In the basic position adjusting is not necessary. The knives and chip limitors are fixed to each

Ausführung:

Messer aus Hochleistungs-Stahl, Messersätze sind zum Nachschleifen, keine Wegwerfmesser! Abweiser werden um das gleiche Maß nachgesetzt. Sehr hohe Standzeit im Vergleich zu SP-Stahl.

Anwendung:

Zum Profilieren von Massivholz im Innenausbau, Möbel- und Modellbau. Flugkreis verstellbar für Arbeiten am Anlaufing beidseitig schwenkbar zum Korrigieren und Verändern von Profilen, sehr vielseitig und leistungsstark.

Technical details

Application of the cutterhead see previous page. Standard-profile knives made of high alloyed steel. The knife set is regrindable. No throw away knives! After grinding the knives, diameter of chip limitors must be adjusted. Very high working life compared with SP-steel.

Application:

For the profiling of solid wood interior work, furniture- and model constructions. Cutting circle adjustable for working with a guide ring. Pivotal on both sides for the correction and alternation of profiles. Very versatile and powerful.

Sie dürfen ...

Ihren Unikopf mit Messersätzen selbst zusammenstellen. Je nach Ihren Bedürfnissen, Wünschen und Anforderungen können Sie zwischen 100mm und 120mm Kopfdurchmesser, 30mm oder 40mm Bohrung sowie zwischen 56 verschiedenen Messersätzen wählen. Alle Messersätze sind preisgleich. Sie können die Anzahl der Profile somit selbst bestimmen.

You may ...

compose your universal cutterhead with knife sets yourselves. According to your requirements, you can choose between 100mm and 120mm head diameter, 30mm or 40mm bore as well as 56 different knife sets. All knife sets are the same price. Therefore you can determine the number of profiles yourselves.

Bestellungsbeispiel für 250/10:

Ordering example for 250/10:

- 1 Sicherheits-Universalmesserkopf
Safety-universal cutterhead
Nr./No. 250/11.80 100ØX40X30mm BG-TEST
je 1 Messersatz (2 Messer und 2 Abweiser) HL
1 Knife set (2 knives and 2 limitors) HL

- Bestell Nr. / Part No. 250/11.03 Profil / Profile -3-
- Bestell Nr. / Part No. 250/11.07 Profil / Profile -7-
- Bestell Nr. / Part No. 250/11.39 Profil / Profile -39-
- Bestell Nr. / Part No. 250/11.12 Profil / Profile -12-
- Bestell Nr. / Part No. 250/11.15 Profil / Profile -15-
- Bestell Nr. / Part No. 250/11.21 Profil / Profile -21-
- Bestell Nr. / Part No. 250/11.23 Profil / Profile -23-
- Bestell Nr. / Part No. 250/11.28 Profil / Profile -28-
- Bestell Nr. / Part No. 250/11.30 Profil / Profile -30-
- Bestell Nr. / Part No. 250/11.40 Profil / Profile -40-

250/10 Universalmesserkopf mit 10 Messersätzen frei wählbar

250/10 Universal cutterhead with 10 knife sets free choice **250/10**

Bestehend aus:

Bestell-Nr.
Part-No.

- Consisting of:
- 1 Sicherheits-Universalmesserkopf 100X40X30 mm mit Spannelementen und Schlüsseln
Safety universal cutterhead 100X40X30 mm with clamping elements and keys
- 10 Paar Profilmesser mit Abweiser/Profile frei wählbar
Pairs of profile knives with limitors; free choice

Komplett / Complete

250/10

250/20 Universalmesserkopf mit 20 Messersätzen frei wählbar

250/20 Universal cutterhead with 20 knife sets free choice **250/20**

Bestehend aus:

Bestell-Nr.
Part-No.

- Consisting of:
- 1 Sicherheits-Universalmesserkopf 100X40X30 mm mit Spannelementen und Schlüsseln
Safety universal cutterhead 100X40X30 mm with clamping elements and keys
- 20 Paar Profilmesser mit Abweiser/Profile frei wählbar
Pairs of profile knives with limitors; free choice

Komplett / Complete

250/20

250/40 Universalmesserkopf mit 40 Messersätzen frei wählbar

250/40 Universal cutterhead with 40 knife sets free choice **250/40**

Bestehend aus:

Bestell-Nr.
Part-No.

- Consisting of:
- 1 Sicherheits-Universalmesserkopf 100X40X30 mm mit Spannelementen und Schlüsseln
Safety universal cutterhead 100X40X30 mm with clamping elements and keys
- 40 Paar Profilmesser mit Abweiser/Profile frei wählbar
Pairs of profile knives with limitors; free choice

Komplett / Complete

250/40

**Hochleistungsstahl
für hohe Standwege,
kein SP-Stahl
(keine Wegwerfmesser).**

**HL-steel (high alloyed tool
steel) for long working life,
no SP-steel
(no throw away knives).**

Standard-
Profilmesser
siehe
Folgeseiten

Standard
profile knives
look at the
following
pages

ZU/FOR 250/11

HS SONDER MESSERSÄTZE NACH HOLZMUSTER ODER ZEICHNUNG HSS SPECIAL PROFILE KNIVES AS PER WOOD SAMPLE OR DRAWING

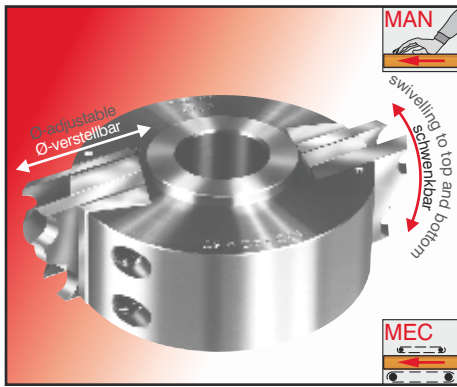

Ausführung:

Messersätze bestehend aus:
2 Profilmessern mit 2 dazugehörigen Abweisern
HS-Stahl.
Für hohe Ansprüche an Standwege.
Keine Wegwerfmesser!
Max. Schnittbreite bei Sonderprofilmessern 44mm.

Anwendung:

Zum Profilieren von Massivholz
im Innenausbau, Möbel- und Modellbau.

Technical details:

Knife sets are consisting of:
2 Profile knives with 2 limiters
HSS steel. For high demands on working life.
No throw away knives!
Max. cutting width of special knives 44mm.

Application:

For profiling solid wood for
interior work, furniture and model constructions.

Nachschleifen:

Die Messer und die Abweiser dürfen nur im
Satz nachgeschliffen werden. Der Abweiser
wird um das gleiche Maß nachgesetzt wie
am Messer weggeschliffen wurde.

Sondermesser in HS Stahl

- Garantie für hohe Standwege -

Regrinding:

The knives and the limiters may only be ground as
a unit. After grinding the knives,
diameter of chip limiters must be adjusted.

Special knives in HSS steel

- Guarantee for long working life -

Die Schleifschablone ist
im Preis bereits enthalten!

The price includes the
template!



Blanketts /Blank knives

HS Blanketts HSS blank knives	Nur für autorisierte Schleifdienste! Only for authorized grinding services!	Bestell-Nr. Part-No.
2 Blanketts mit Abweiser / 2 Blank knives with limiters	39mm	250/11.72
2 Blanketts mit Abweiser / 2 Blank knives with limiters	44mm	250/11.73

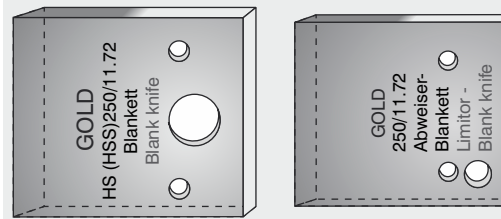

Sonderprofilmesser Profilgruppe I / Special profile knives profile group -I-

HS Messer HSS knives	Gruppe -I- Group -I-	Bestell-Nr. Part-No.
2 Profilmesser mit Abweiser und Schleifschablone nach Zeichnung oder Holzmuster, max. Profilausladung 17 mm		
2 Profile knives with limiters and template as per drawing or wood sample, max. profile depth 17 mm		
39 mm breit Profilgruppe -I- / 39 mm wide profile group -I-		250/11.60
44 mm breit Profilgruppe -I- / 44 mm wide profile group -I-		250/11.61

Beispiele Profilgruppe / Example Profile group -I-

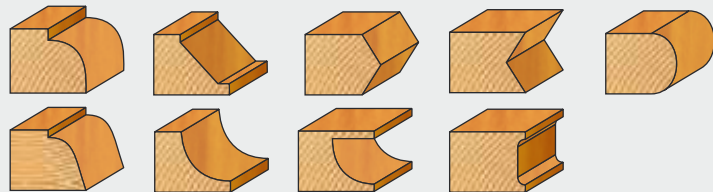

Sonderprofilmesser Profilgruppe II / Special profile knives profile group -II-

HS Messer HSS knives	Gruppe -II- Group -II-	Bestell-Nr. Part-No.
2 Profilmesser mit Abweiser und Schleifschablone nach Zeichnung oder Holzmuster, max. Profilausladung 17 mm		
2 Profile knives with limiters and template as per drawing or wood sample, max. profile depth 17 mm		
39 mm breit Profilgruppe -II- / 39 mm wide profile group -II-		250/11.64
44 mm breit Profilgruppe -II- / 44 mm wide profile group -II-		250/11.65

Beispiele Profilgruppe / Example Profile group -II-

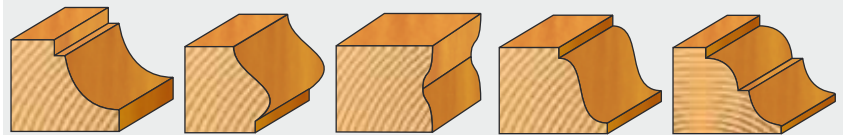

Sonderprofilmesser Profilgruppe III / Special profile knives profile group -III-

HS Messer HSS knives	Gruppe -III- Group -III-	Bestell-Nr. Part-No.
2 Profilmesser mit Abweiser und Schleifschablone nach Zeichnung oder Holzmuster, max. Profilausladung 17 mm		
2 Profile knives with limiters and template as per drawing or wood sample, max. profile depth 17 mm		
39 mm breit Profilgruppe -III- / 39 mm wide profile group -III-		250/11.68
44 mm breit Profilgruppe -III- / 44 mm wide profile group -III-		250/11.69

Beispiele Profilgruppe / Example Profile group -III-

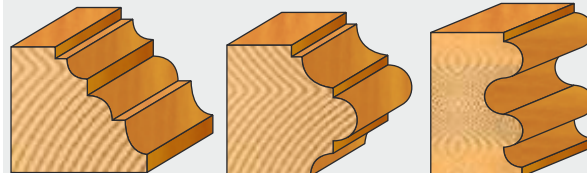

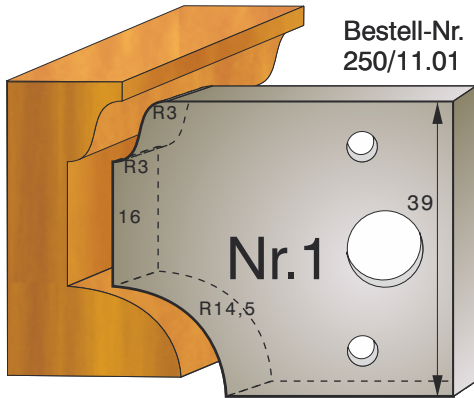

Standardmessersätze Standard knife sets	Bestell-Nr. Part-No.
2 Messer / Knives HL 39 mm + 2 Abweiser / Limitors	250/11.01
2 Messer / Knives HL 39 mm + 2 Abweiser / Limitors	250/11.02
2 Messer / Knives HL 39 mm + 2 Abweiser / Limitors	250/11.03
2 Messer / Knives HL 39 mm + 2 Abweiser / Limitors	250/11.04
2 Messer / Knives HL 39 mm + 2 Abweiser / Limitors	250/11.05
2 Messer / Knives HL 39 mm + 2 Abweiser / Limitors	250/11.06
2 Messer / Knives HL 39 mm + 2 Abweiser / Limitors	250/11.07
2 Messer / Knives HL 39 mm + 2 Abweiser / Limitors	250/11.08
2 Messer / Knives HL 39 mm + 2 Abweiser / Limitors	250/11.09
2 Messer / Knives HL 39 mm + 2 Abweiser / Limitors	250/11.10

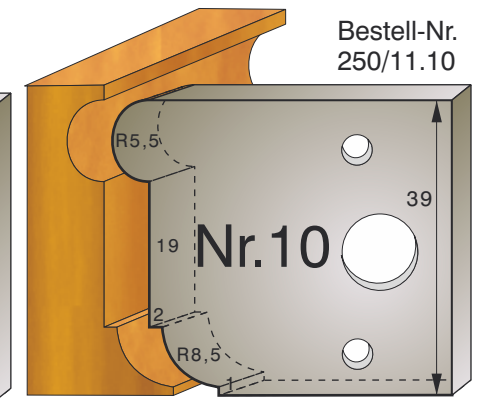
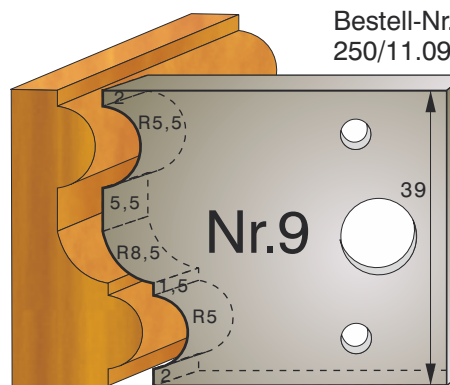
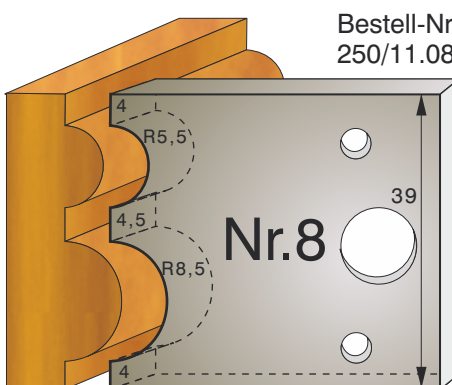
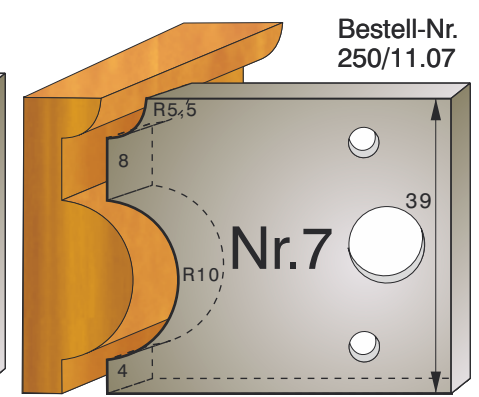
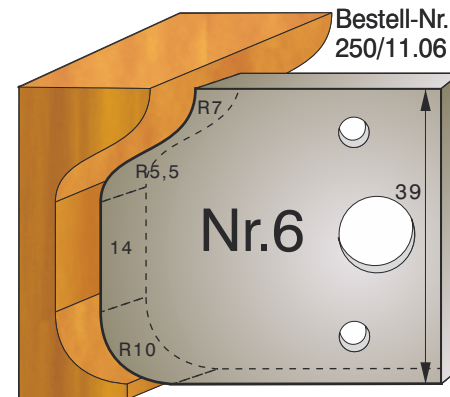
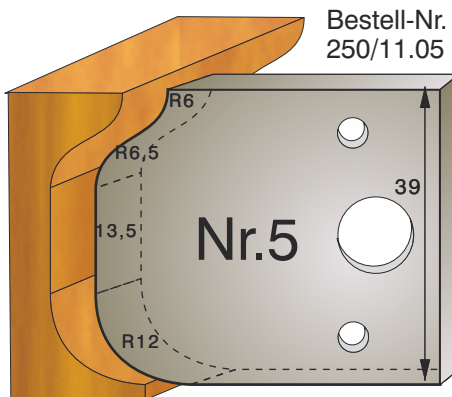
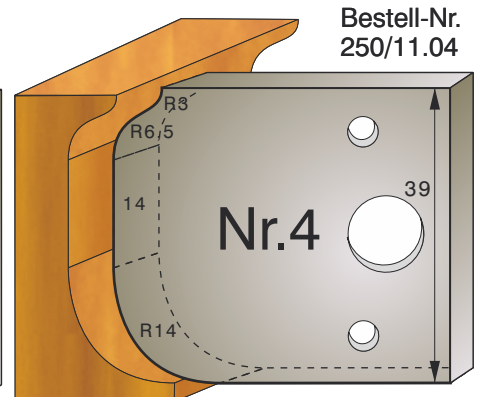
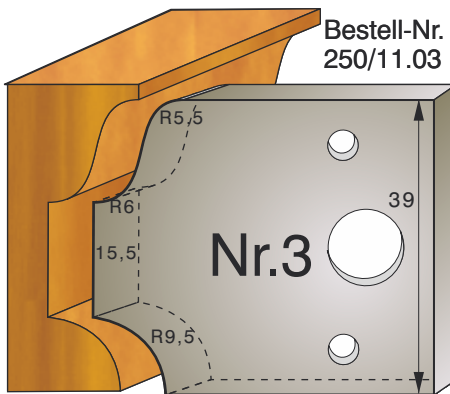
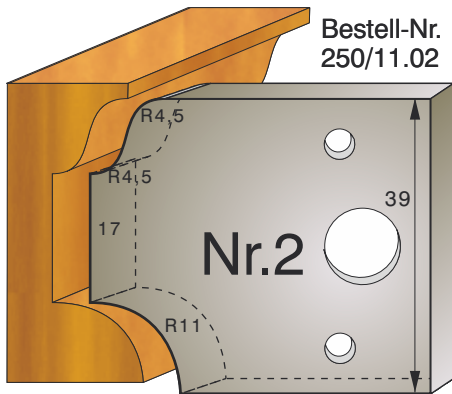

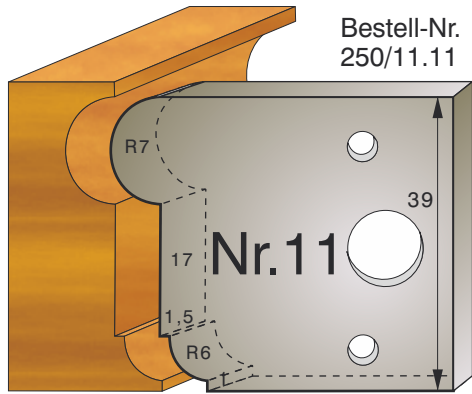

Bestell-Nr.
250/11.11

Standardmessersätze Standard knife sets	Bestell-Nr. Part-No.
2 Messer / Knives HL 39 mm + 2 Abweiser / Limitors	250/11.11
2 Messer / Knives HL 39 mm + 2 Abweiser / Limitors	250/11.12
2 Messer / Knives HL 39 mm + 2 Abweiser / Limitors	250/11.13
2 Messer / Knives HL 39 mm + 2 Abweiser / Limitors	250/11.14
2 Messer / Knives HL 39 mm + 2 Abweiser / Limitors	250/11.15
2 Messer / Knives HL 39 mm + 2 Abweiser / Limitors	250/11.16
2 Messer / Knives HL 39 mm + 2 Abweiser / Limitors	250/11.17
2 Messer / Knives HL 39 mm + 2 Abweiser / Limitors	250/11.18
2 Messer / Knives HL 39 mm + 2 Abweiser / Limitors	250/11.19
2 Messer / Knives HL 39 mm + 2 Abweiser / Limitors	250/11.20

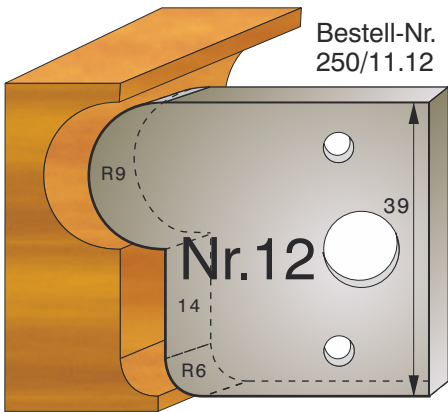

Bestell-Nr.
250/11.12

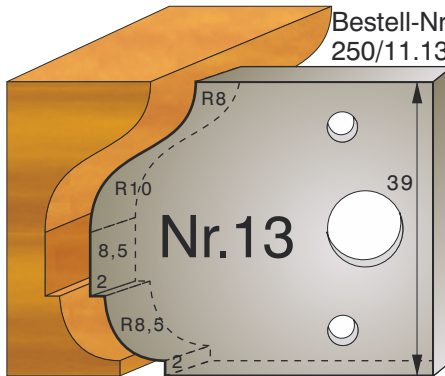

Bestell-Nr.
250/11.13

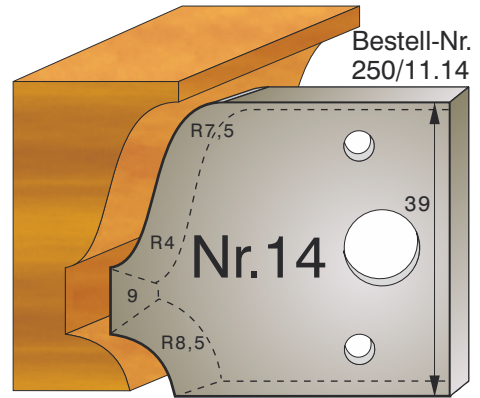

Bestell-Nr.
250/11.14

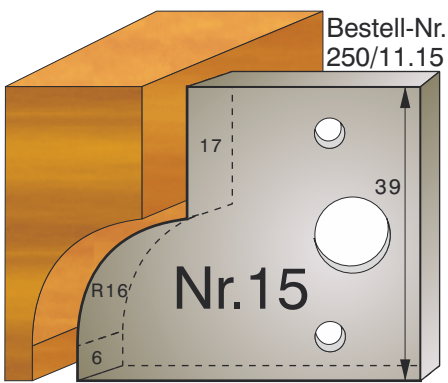

Bestell-Nr.
250/11.15

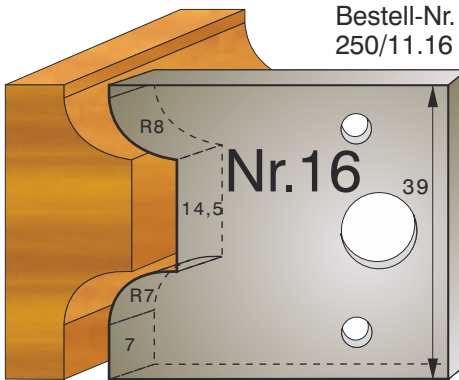

Bestell-Nr.
250/11.16

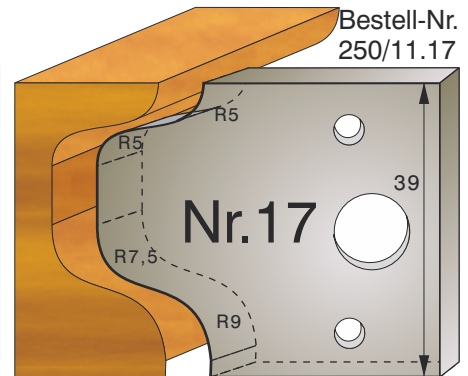

Bestell-Nr.
250/11.17

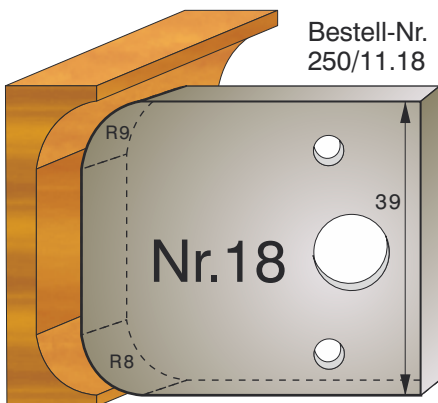

Bestell-Nr.
250/11.18

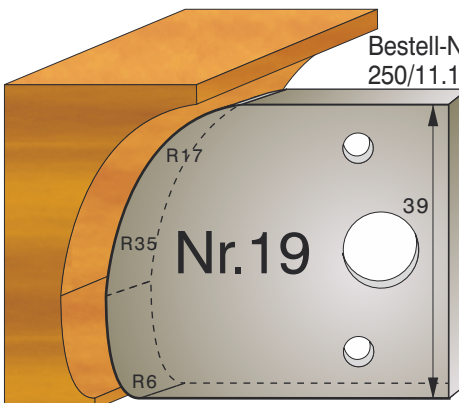

Bestell-Nr.
250/11.19

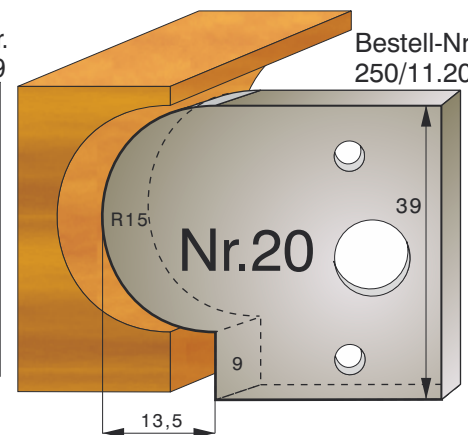

Bestell-Nr.
250/11.20

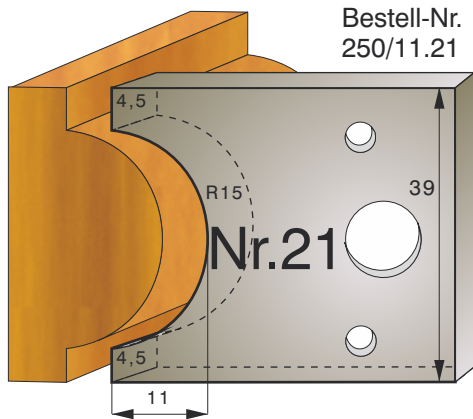

Bestell-Nr.
250/11.21

Standardmessersätze
Standard knife sets

2 Messer / Knives HL 39 mm + 2 Abweiser / Limitors	250/11.21
2 Messer / Knives HL 39 mm + 2 Abweiser / Limitors	250/11.22
2 Messer / Knives HL 39 mm + 2 Abweiser / Limitors	250/11.23
2 Messer / Knives HL 39 mm + 2 Abweiser / Limitors	250/11.24
2 Messer / Knives HL 39 mm + 2 Abweiser / Limitors	250/11.25
2 Messer / Knives HL 39 mm + 2 Abweiser / Limitors	250/11.26
2 Messer / Knives HL 39 mm + 2 Abweiser / Limitors	250/11.27
2 Messer / Knives HL 39 mm + 2 Abweiser / Limitors	250/11.28
2 Messer / Knives HL 39 mm + 2 Abweiser / Limitors	250/11.29
2 Messer / Knives HL 39 mm + 2 Abweiser / Limitors	250/11.30

Bestell-Nr.
Part-No.

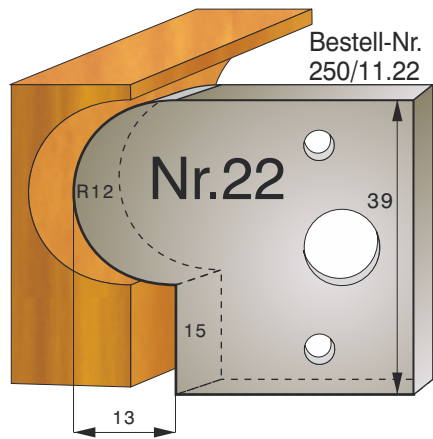

Bestell-Nr.
250/11.22

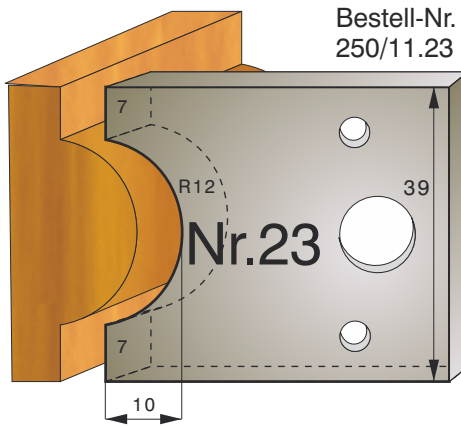

Bestell-Nr.
250/11.23

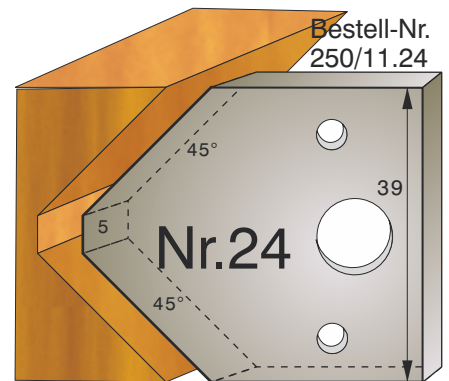

Bestell-Nr.
250/11.24

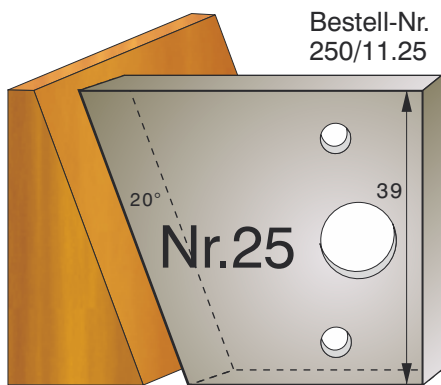

Bestell-Nr.
250/11.25

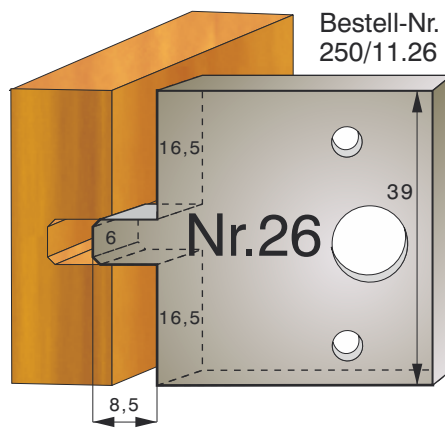

Bestell-Nr.
250/11.26

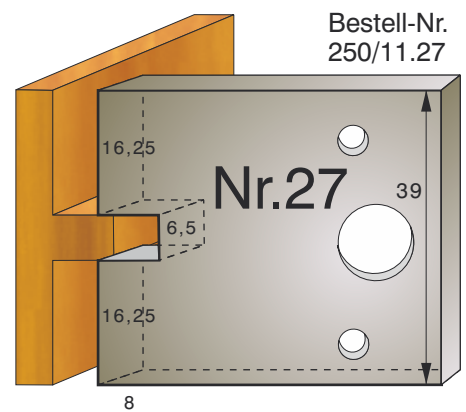

Bestell-Nr.
250/11.27

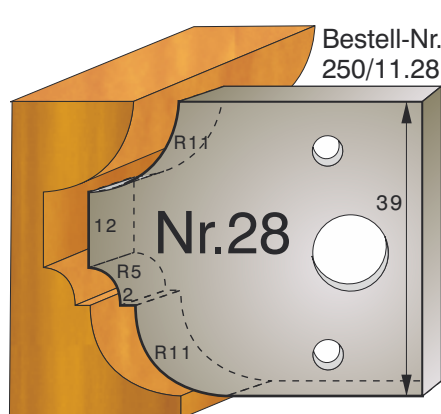

Bestell-Nr.
250/11.28

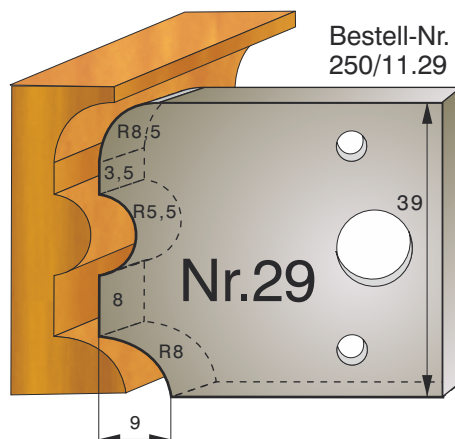

Bestell-Nr.
250/11.29

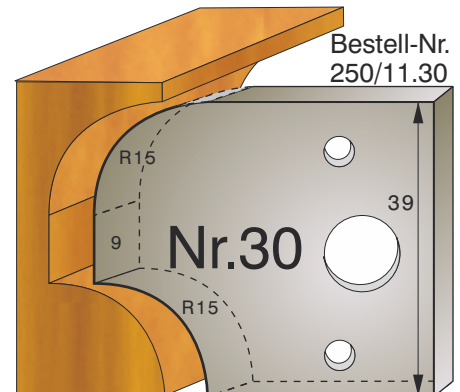

Bestell-Nr.
250/11.30

1

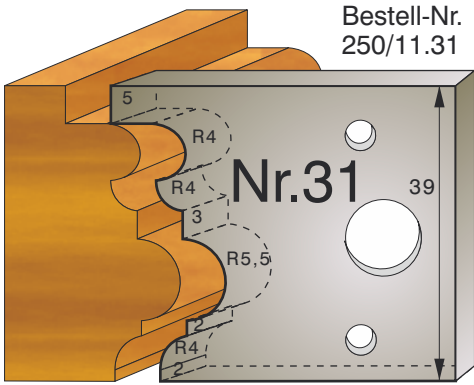

Bestell-Nr.
250/11.31

Standardmessersätze
Standard knife sets

Bestell-Nr.
Part-No.

2 Messer / Knives HL 39 mm + 2 Abweiser / Limitors	250/11.31
2 Messer / Knives HL 44 mm + 2 Abweiser / Limitors	250/11.32
2 Messer / Knives HL 44 mm + 2 Abweiser / Limitors	250/11.33
2 Messer / Knives HL 44 mm + 2 Abweiser / Limitors	250/11.34
2 Messer / Knives HL 39 mm + 2 Abweiser / Limitors	250/11.35
2 Messer / Knives HL 39 mm + 2 Abweiser / Limitors	250/11.36
2 Messer / Knives HL 44 mm + 2 Abweiser / Limitors	250/11.37
2 Messer / Knives HL 39 mm + 2 Abweiser / Limitors	250/11.38
2 Messer / Knives HL 39 mm + 2 Abweiser / Limitors	250/11.39
2 Messer / Knives HL 39 mm + 2 Abweiser / Limitors	250/11.40

2

3

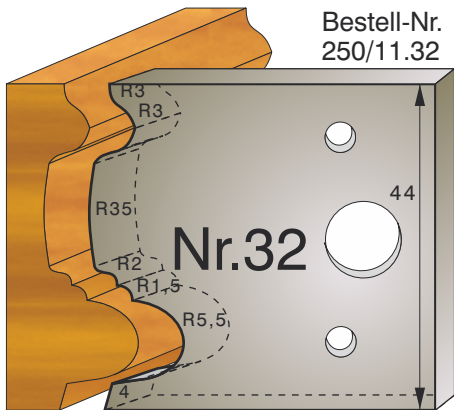

Bestell-Nr.
250/11.32

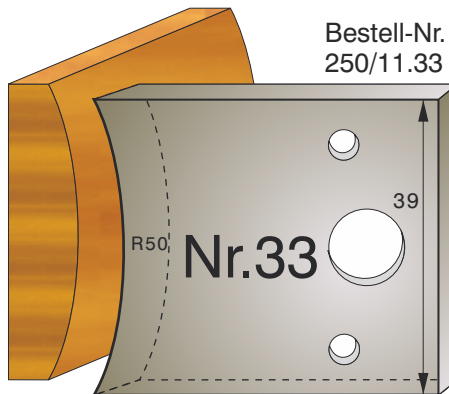

Bestell-Nr.
250/11.33

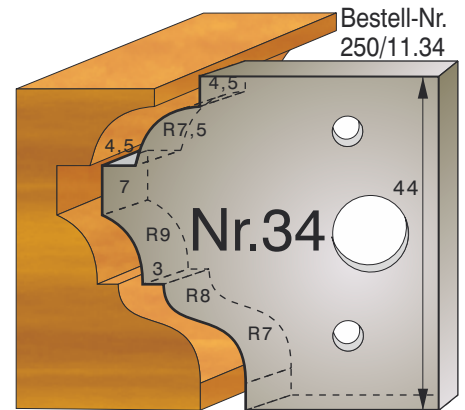

Bestell-Nr.
250/11.34

4

5

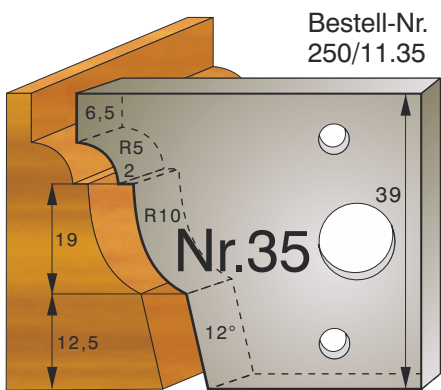

Bestell-Nr.
250/11.35

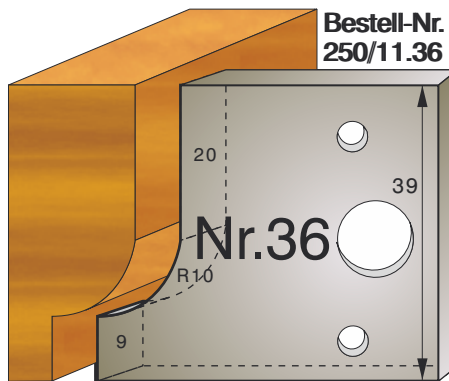

Bestell-Nr.
250/11.36

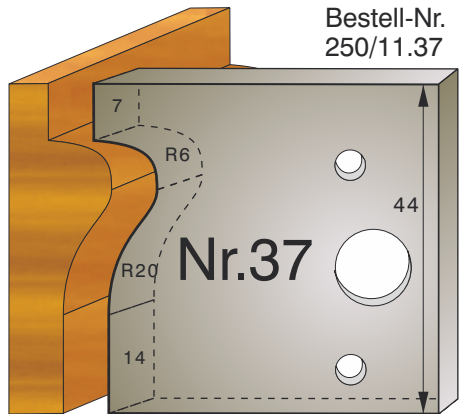

Bestell-Nr.
250/11.37

7

8

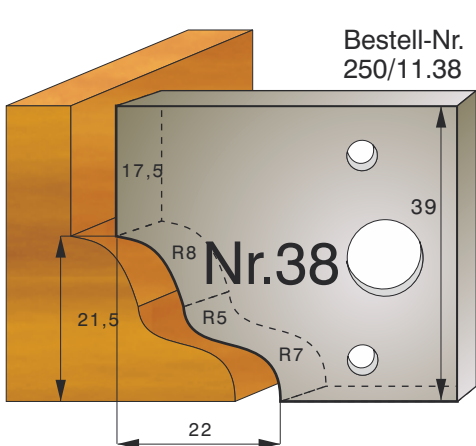

Bestell-Nr.
250/11.38

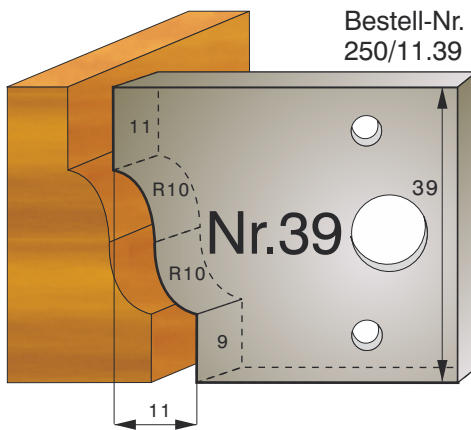

Bestell-Nr.
250/11.39

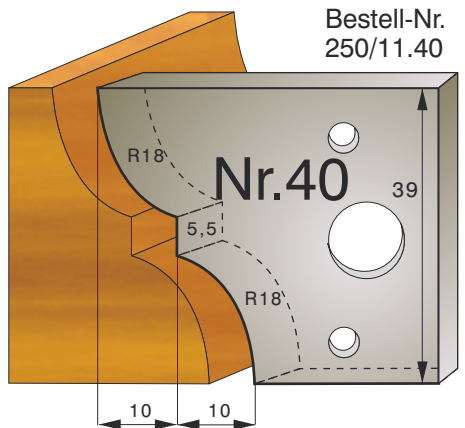

Bestell-Nr.
250/11.40

10

11

12

Standardmessersätze Standard knife sets	Bestell-Nr. Part-No.
2 Messer / Knives HL 39 mm + 2 Abweiser / Limitors	250/11.411
2 Messer / Knives HL 39 mm + 2 Abweiser / Limitors	250/11.412
2 Messer / Knives HL 39 mm + 2 Abweiser / Limitors	250/11.413
2 Messer / Knives HL 39 mm + 2 Abweiser / Limitors	250/11.414
2 Messer / Knives HL 39 mm + 2 Abweiser / Limitors	250/11.415
2 Messer / Knives HL 39 mm + 2 Abweiser / Limitors	250/11.416
2 Messer / Knives HL 39 mm + 2 Abweiser / Limitors	250/11.417
2 Messer / Knives HL 39 mm + 2 Abweiser / Limitors	250/11.418
2 Messer / Knives HL 39 mm + 2 Abweiser / Limitors	250/11.42
2 Messer / Knives HL 39 mm + 2 Abweiser / Limitors	250/11.43
2 Messer / Knives HL 39 mm + 2 Abweiser / Limitors	250/11.44
2 Messer / Knives HL 39 mm + 2 Abweiser / Limitors	250/11.45
2 Messer / Knives HL 39 mm + 2 Abweiser / Limitors	250/11.46

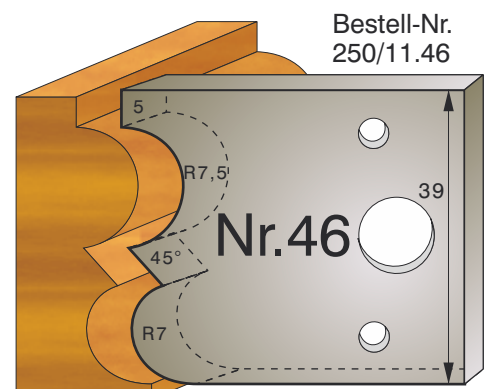
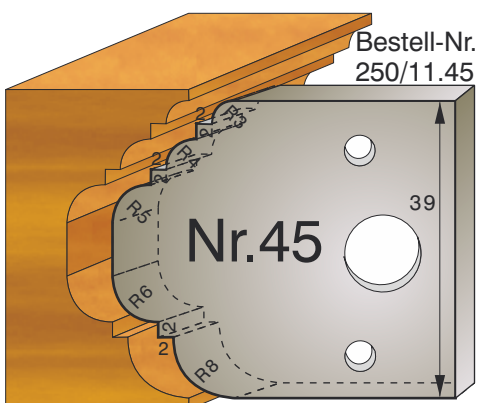
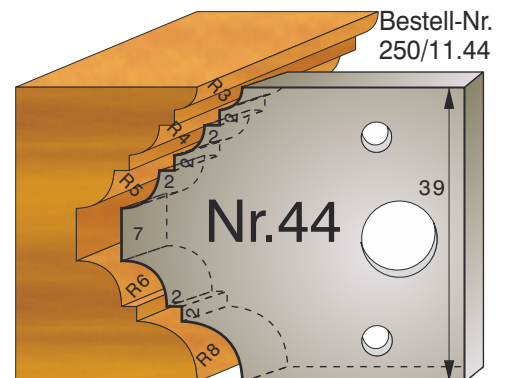
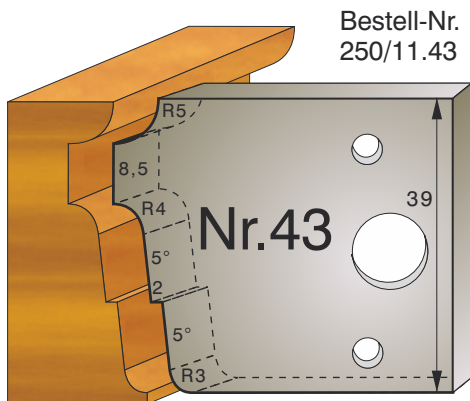
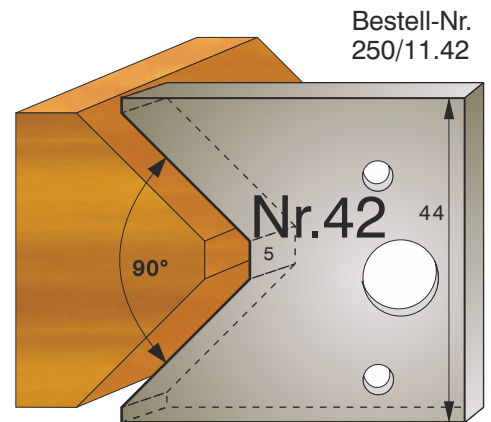
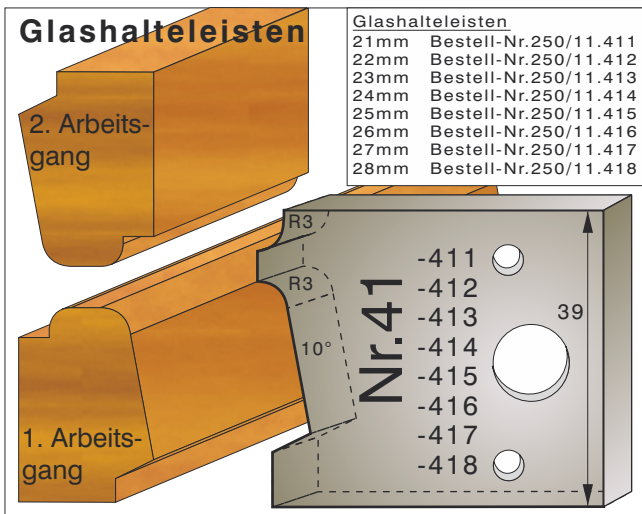

1

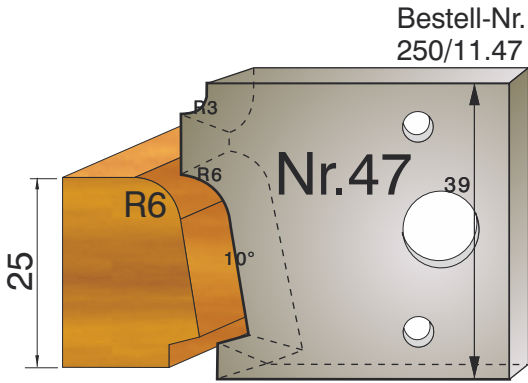

Standardmessersätze
Standard knife sets

- 2 Messer / Knives HL 39 mm + 2 Abweiser / Limitors
- 2 Messer / Knives HL 39 mm + 2 Abweiser / Limitors
- 2 Messer / Knives HL 44 mm + 2 Abweiser / Limitors
- 2 Messer / Knives HL 39 mm + 2 Abweiser / Limitors
- 2 Messer / Knives HL 39 mm + 2 Abweiser / Limitors
- 2 Messer / Knives HL 39 mm + 2 Abweiser / Limitors
- 2 Messer / Knives HL 39 mm + 2 Abweiser / Limitors
- 2 Messer / Knives HL 39 mm + 2 Abweiser / Limitors
- 2 Messer / Knives HL 39 mm + 2 Abweiser / Limitors
- 2 Messer / Knives HL 39 mm + 2 Abweiser / Limitors

Bestell-Nr.
Part-No.

- 250/11.47
- 250/11.48
- 250/11.49
- 250/11.50
- 250/11.51
- 250/11.52
- 250/11.53
- 250/11.54
- 250/11.55
- 250/11.56

2

3

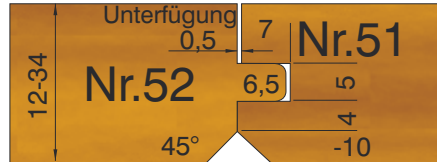

4

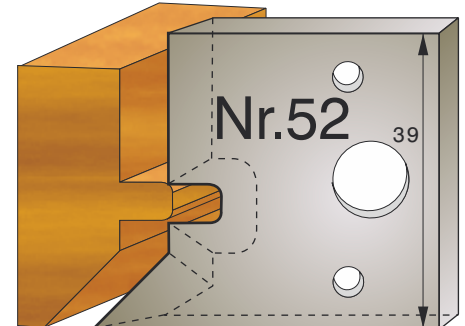
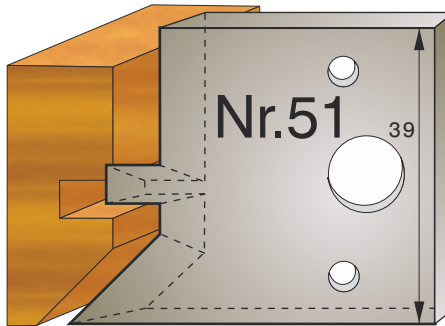
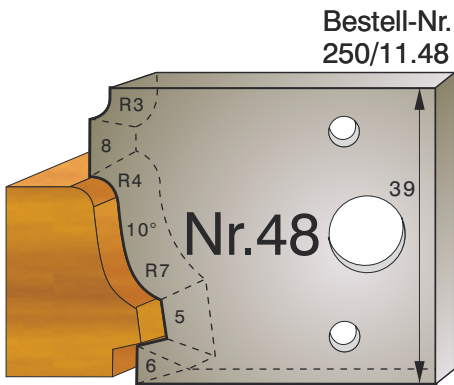

5

6

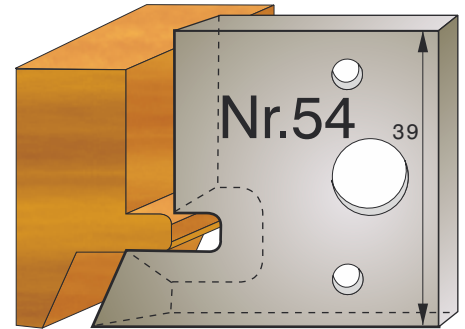
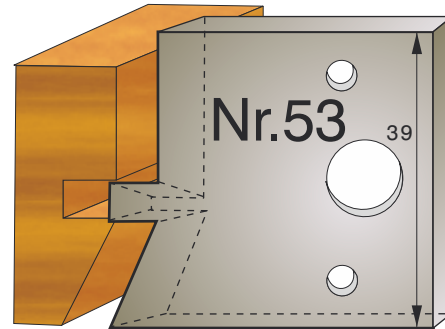
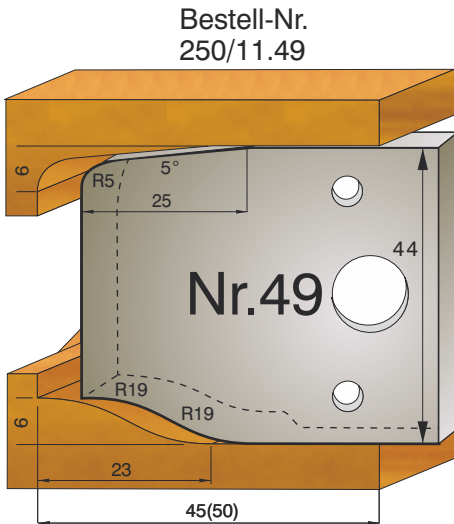

7

8

9

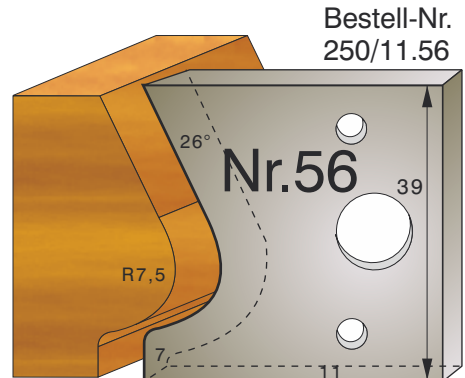
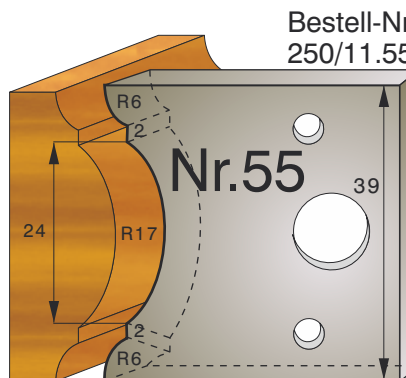
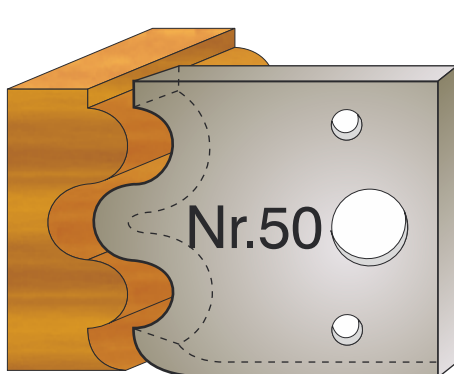

10

11

12

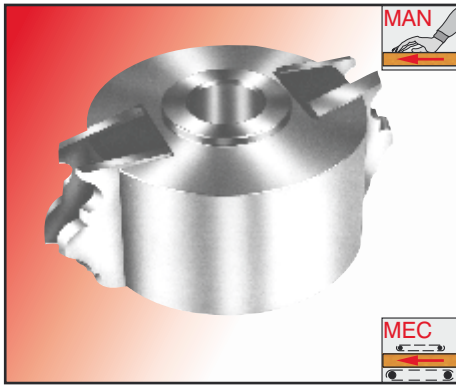

Ausführung:

Grundkörper aus elastischem Stahl, 2 achsparallele Messer mit Abweisern, formschlüssige Messerbefestigung, Messer und Abweiser fest zueinander fixiert dadurch keinerlei Einstellarbeiten notwendig.
Sicherer und schneller Messerwechsel zum Einsatz mit Standardprofilmessern oder mit Sondermessern nach Holzmuster bzw. Zeichnung.
Max. Schnittbreite bei Sondermessern 64mm
n: 4500-6000

Anwendung:

Zum Profilieren von Massivholz im Innenausbau, Möbel- und Modellbau, sehr vielseitig und leistungsstark.

Technical details

Tool body of elastic steel.
2 straight knives with limitors.
Knives and limitors are fixed together, thereby no adjustment. Fast and safe knife change. For the insertion of standard profile knives or special profile knives as per wood sample or drawing.
Max. cutting width of special knives 64mm.
R.P.M.: 4500-6000

Application:

For profiling of solid wood for interior work, furniture- and model construction. Very versatile and powerful.

Passende Standard-Messersätze finden Sie auf den Folgeseiten.
Suitable standard knife sets please see the following pages.

Die Schleifschablone ist im Preis bereits enthalten!
The price includes the template!



Messerkopf und Ersatzteile / Cutterhead and spare parts

ØD X B X Ød ØD X W X Ød	Z T		Bestell-Nr. Part-No.
110 X 59 X 30 mm	2	Mit Spannkeil - Ohne Messer With clamping wedges- Without knives	260.30
120 X 59 X 30 mm	2	Mit Spannkeil - Ohne Messer With clamping wedges- Without knives	260.31
120 X 59 X 35 mm	2	Mit Spannkeil - Ohne Messer With clamping wedges- Without knives	260.32
120 X 59 X 40 mm	2	Mit Spannkeil - Ohne Messer With clamping wedges- Without knives	260.33

Spannschraube alte Ausführung Clamping screw old type	260.36
Spannschraube neue Ausführung Clamping screw new type	260.39
Ersatzschlüssel / Spare key	260.37
2 Blanketts HS mit Abweiser 59mm (nur für autorisierte Schleifdienste) Blank knives HSS with limitors 59mm (only for authorized grinding services)	260.60
2 Blanketts HS mit Abweiser 64mm (nur für autorisierte Schleifdienste) Blank knives HSS with limitors 64mm (only for authorized grinding services)	260.61
Schleifschablone für Profilmesser / Template for profile knives -extra	260.38

Sonderprofilmesser Special profile knives	Gruppe -I- Group -I-	Bestell-Nr. Part-No.
2 Messer HS/Knives HSS + Abweiser/Limitors + Schleifschablone/Template nach Zeichnung oder Holzmuster, max. Profilausladung 27 mm as per drawing or wood sample, max. profile depth 27 mm		
59 mm Profilgruppe -I- komplett / Profile group -I- complete		260.51
64 mm Profilgruppe -I- komplett / Profile group -I- complete		260.52

Beispiele Profilgruppe/Example profile group -I-

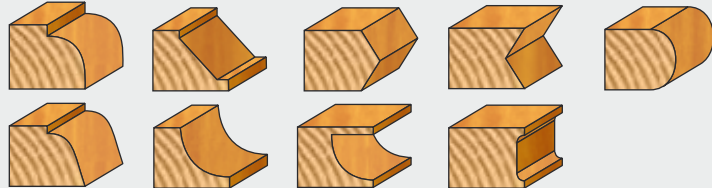

Sonderprofilmesser Special profile knives	Gruppe -II- Group -II-	Bestell-Nr. Part-No.
2 Messer HS/Knives HSS + Abweiser/Limitors + Schleifschablone/Template nach Zeichnung oder Holzmuster, max. Profilausladung 27 mm as per drawing or wood sample, max. profile depth 27 mm		
59 mm Profilgruppe -II- komplett / Profile group -II- complete		260.54
64 mm Profilgruppe -II- komplett / Profile group -II- complete		260.55

Beispiele Profilgruppe/Example profile group -II-

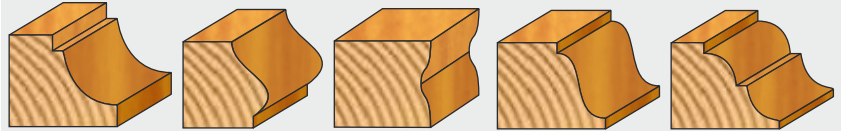

Sonderprofilmesser Special profile knives	Gruppe -III- Group -III-	Bestell-Nr. Part-No.
2 Messer HS/Knives HSS + Abweiser/Limitors + Schleifschablone/Template nach Zeichnung oder Holzmuster, max. Profilausladung 27 mm as per drawing or wood sample, max. profile depth 27 mm		
59 mm Profilgruppe -III- komplett / Profile group -III- complete		260.57
64 mm Profilgruppe -III- komplett / Profile group -III- complete		260.58

Beispiele Profilgruppe/Example profile group -III-

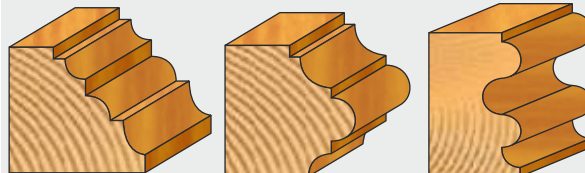

Standardmessersätze Standard knife sets	Bestell-Nr. Part-No.
2 Messer/Knives HS 59mm + 2 Abweiser/LimitersNr. 1-Komplett/Complete	260.01
2 Messer/Knives HS 59mm + 2 Abweiser/LimitersNr. 2-Komplett/Complete	260.02
2 Messer/Knives HS 59mm + 2 Abweiser/LimitersNr. 3-Komplett/Complete	260.03
2 Messer/Knives HS 64mm + 2 Abweiser/LimitersNr. 4-Komplett/Complete	260.04
2 Messer/Knives HS 59mm + 2 Abweiser/LimitersNr. 5-Komplett/Complete	260.05
2 Messer/Knives HS 64mm + 2 Abweiser/LimitersNr. 7-Komplett/Complete	260.07

**Bestell Nr.
260.01**

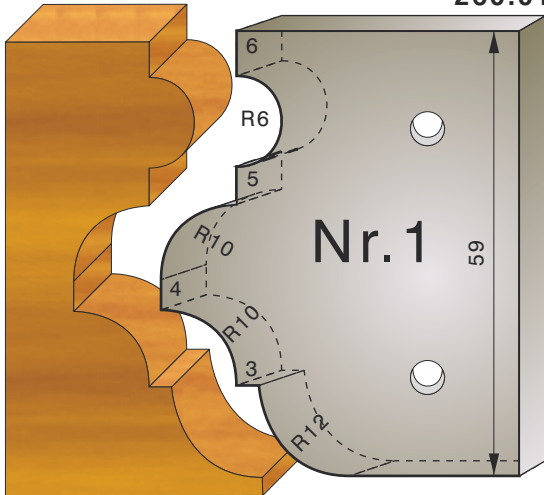

**Bestell Nr.
260.02**

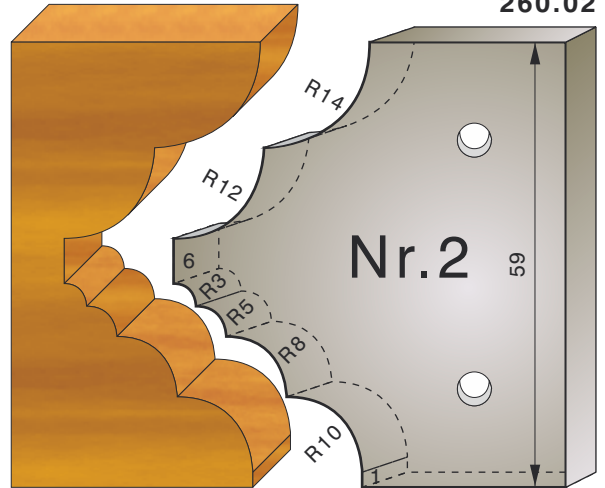

**Bestell Nr.
260.03**

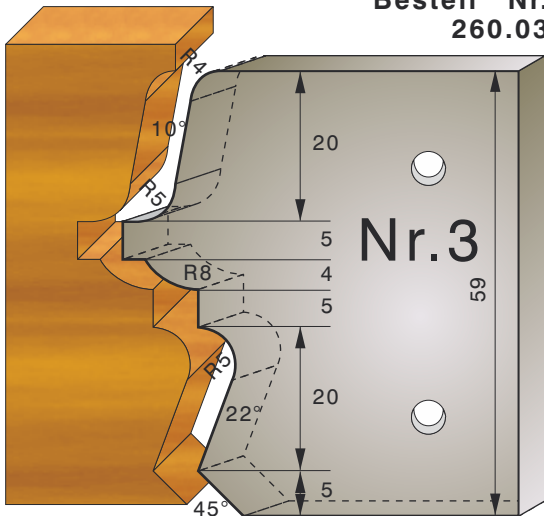

**Bestell Nr.
260.04**

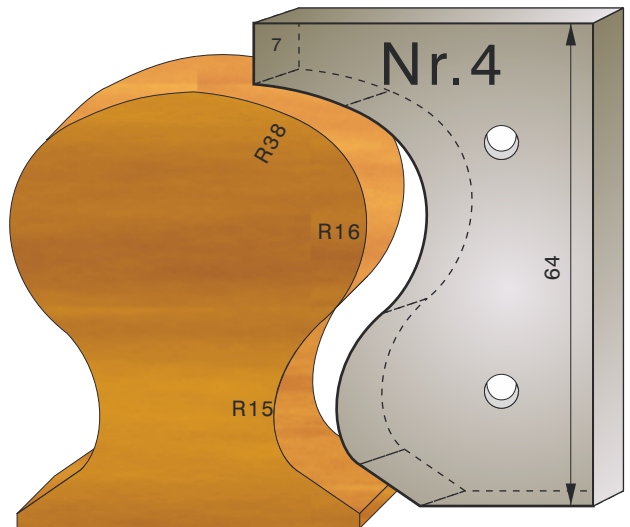

**Bestell Nr.
260.05**

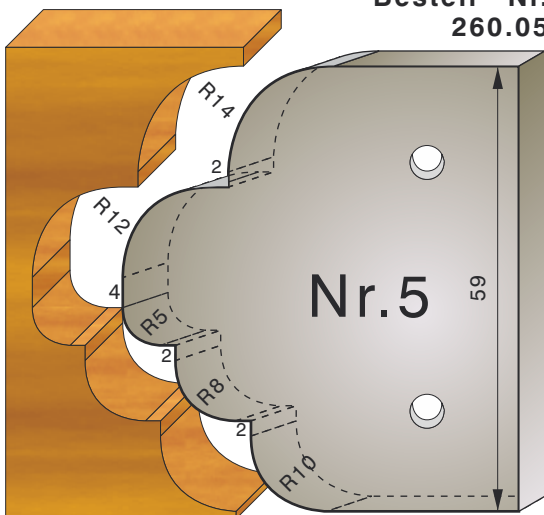

**Bestell Nr.
260.07**

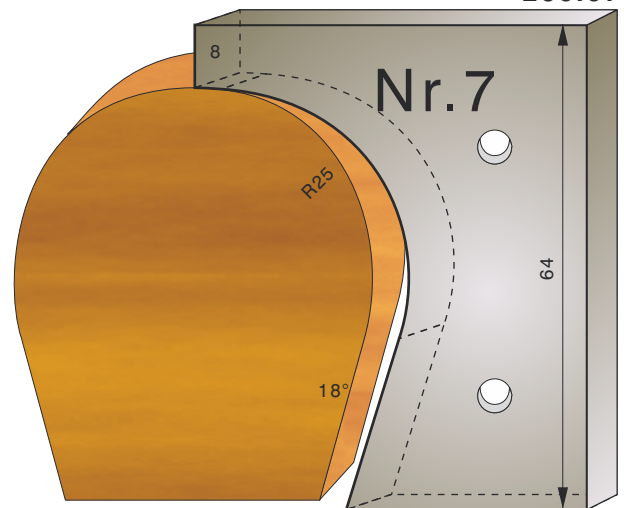

ZU/FOR 260

STANDARD-MESSERSÄTZE HS-STAHL NR. 6, 8, 9 STANDARD-KNIFE SETS HSS-STEEL NO. 6, 8, 9

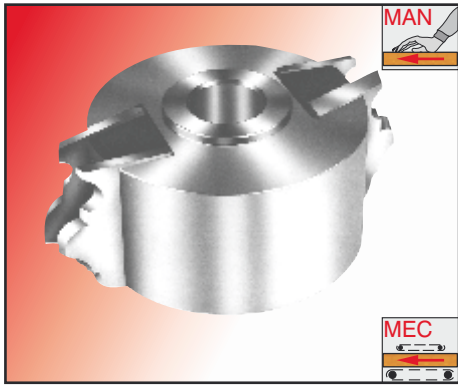

Standardmessersätze
Standard knife sets

Bestell-Nr.
Part-No.

2 Messer/Knives HS 59mm + 2 Abweiser/LimitersNr. 6-Komplett/Complete	260.06
2 Messer/Knives HS 64mm + 2 Abweiser/LimitersNr. 8-Komplett/Complete	260.08
2 Messer/Knives HS 59mm + 2 Abweiser/LimitersNr. 9-Komplett/Complete	260.09

Anlaufriingsatz zu Messersatz Nr. 6
Guide ring set for the knife set No. 6

Bestell-Nr.
Part-No.

Anlaufriingsatz bestehend aus / Guide ring set consists of:

1 Kugellager-Leerlaufbüchse / Ball bearing

je 1 Anlaufring für Außen-und Innenbogen

Guide ring set for outside and inside of arched beads

Komplett 3-teilig für 30 mm Bohrung
Complete 3-parts for 30 mm bore

260.500

Komplett 3-teilig für 40 mm Bohrung
Complete 3-parts for 40 mm bore

260.501

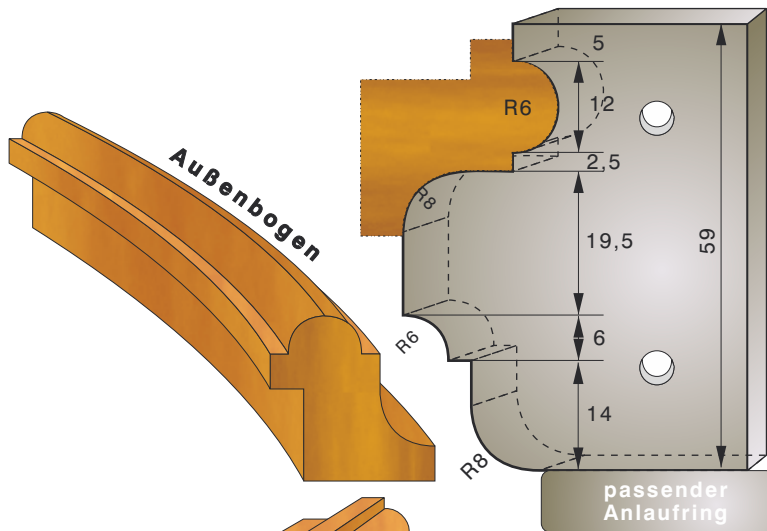

Bestell Nr.
260.08

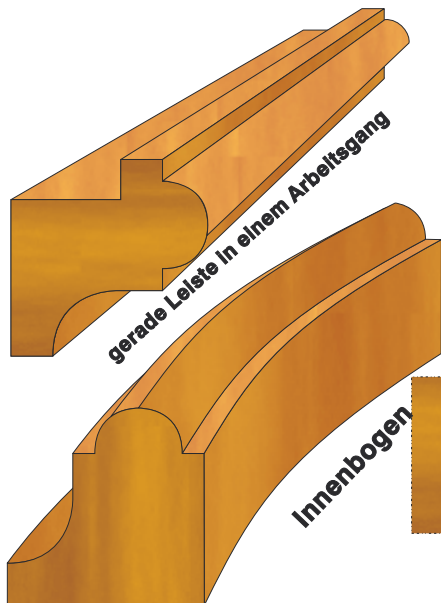
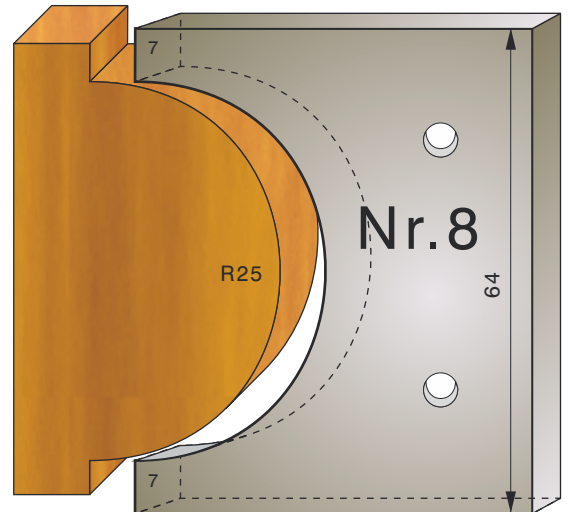

Bestell Nr.
260.09

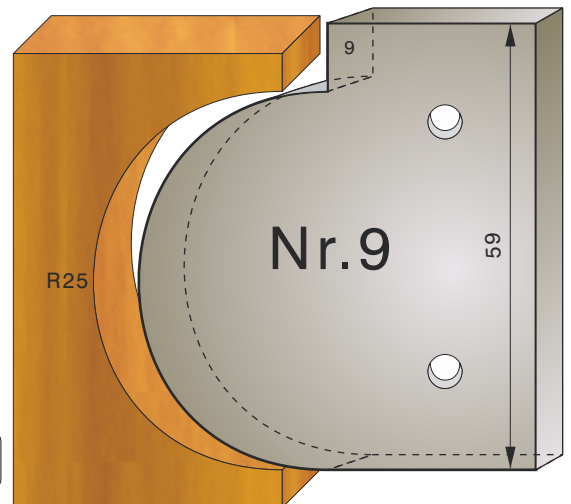

Standardmessersätze
Standard knife sets

Bestell-Nr.
Part-No.

2 Messer/Knives HS 59mm + 2 Abweiser/LimitersNr. 10-Komplett/Complete 260.10

2 Messer/Knives HS 59mm + 2 Abweiser/LimitersNr. 11-Komplett/Complete 260.11

2 Messer/Knives HS 59mm + 2 Abweiser/LimitersNr. 12-Komplett/Complete 260.12

2 Messer/Knives HS 59mm + 2 Abweiser/LimitersNr. 13-Komplett/Complete 260.13

2 Messer/Knives HS 64mm + 2 Abweiser/LimitersNr. 14-Komplett/Complete 260.14

2 Messer/Knives HS 64mm + 2 Abweiser/LimitersNr. 15-Komplett/Complete 260.15

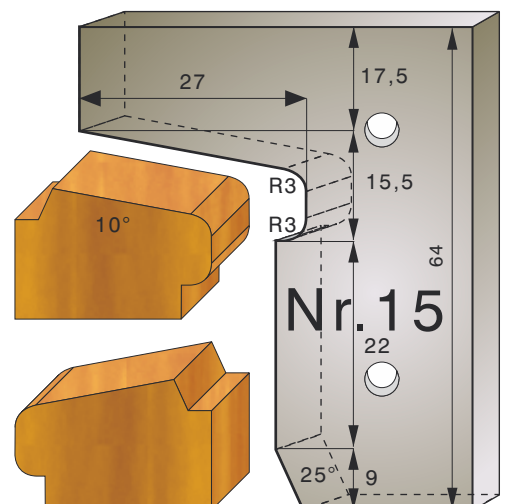
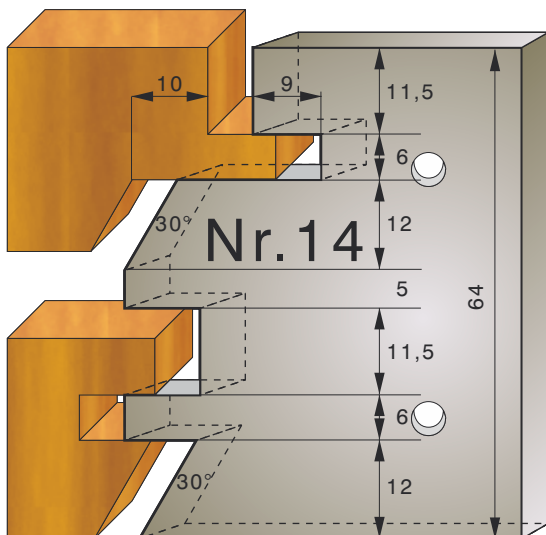
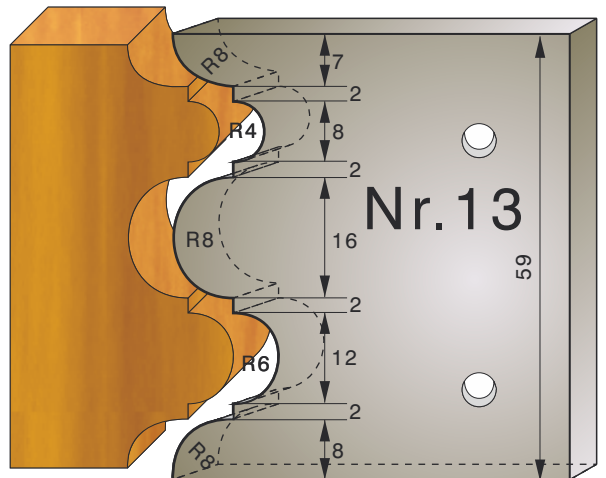
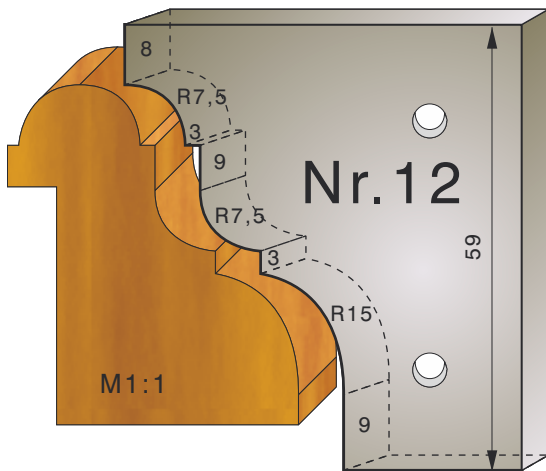
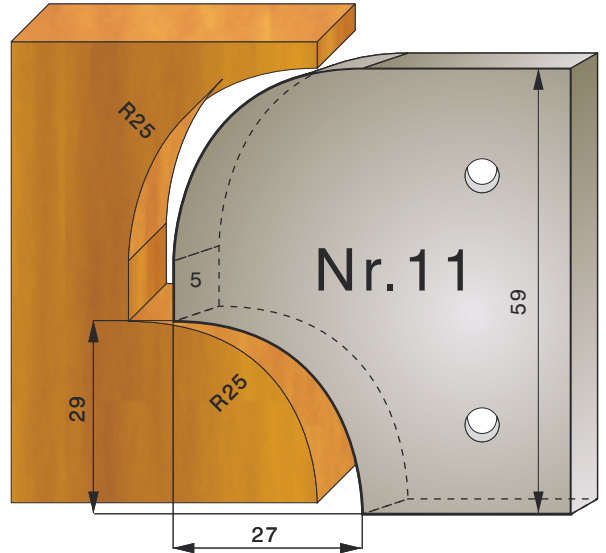
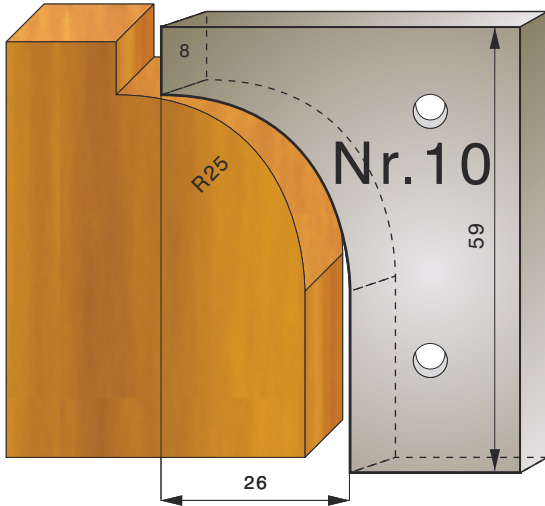

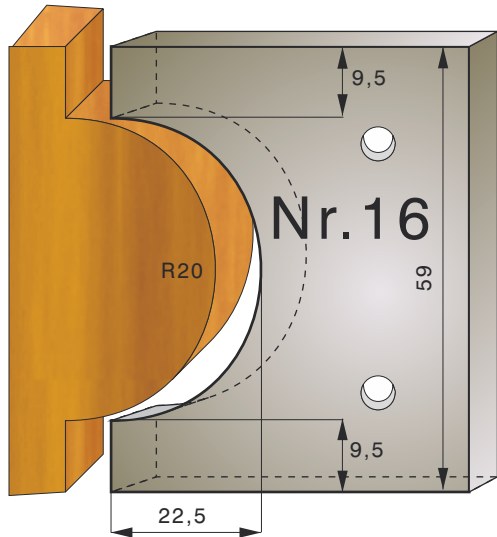

Standardmessersätze
Standard knife sets

Bestell-Nr.
Part-No.

- 2 Messer/Knives HS 59mm + 2 Abweiser/LimitersNr. 16-Komplett/Complete 260.16
- 2 Messer/Knives HS 59mm + 2 Abweiser/LimitersNr. 17-Komplett/Complete 260.17
- 2 Messer/Knives HS 59mm + 2 Abweiser/LimitersNr. 18-Komplett/Complete 260.18
- 2 Messer/Knives HS 59mm + 2 Abweiser/LimitersNr. 19-Komplett/Complete 260.19
- 2 Messer/Knives HS 64mm + 2 Abweiser/LimitersNr. 20-Komplett/Complete 260.20
- 2 Messer/Knives HS 64mm + 2 Abweiser/LimitersNr. 21-Komplett/Complete 260.21

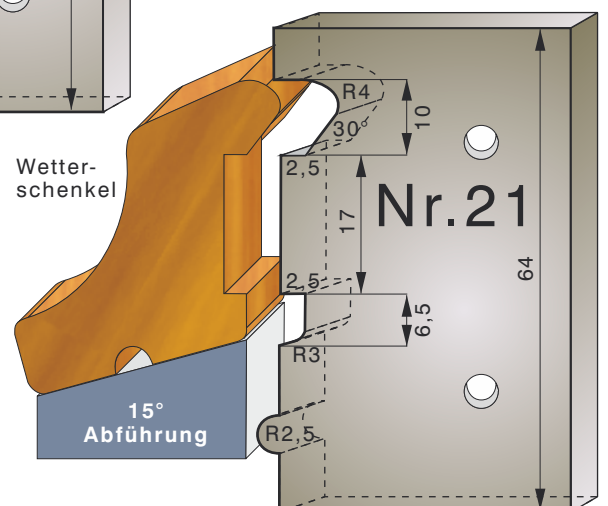
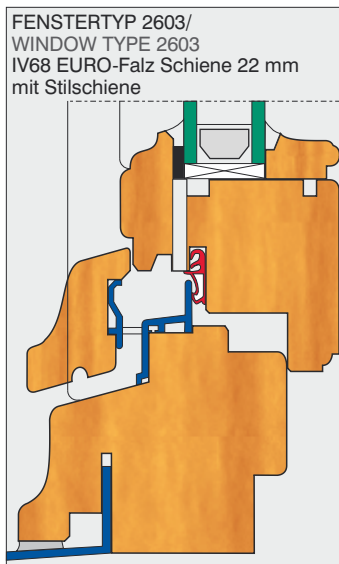
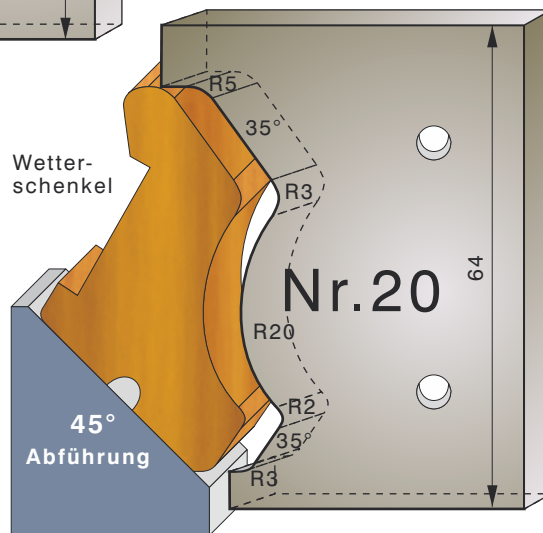
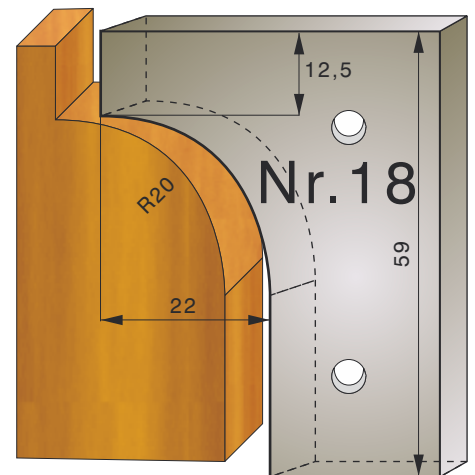
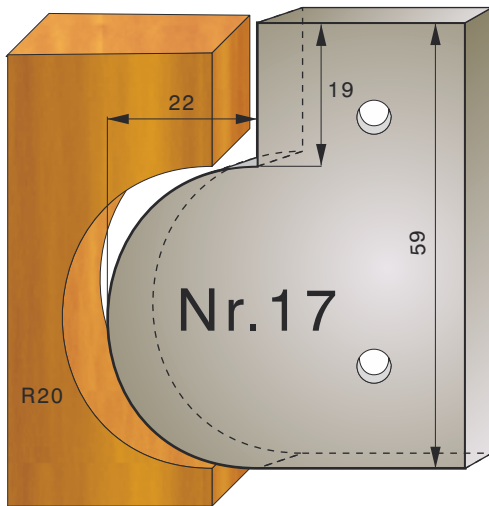
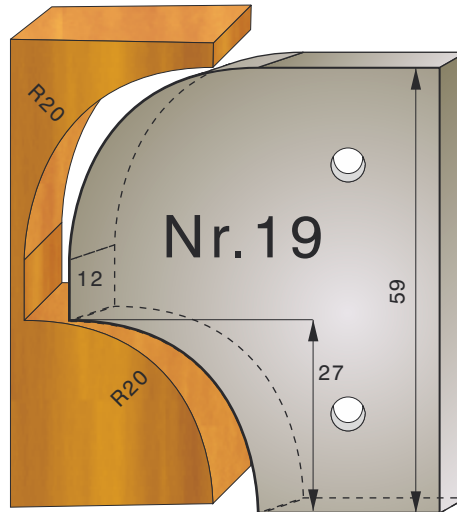

Standardmessersätze
Standard knife sets

Bestell-Nr.
Part-No.

2 Messer/Knives HS 59mm + 2 Abweiser/LimitersNr. 22-Komplett/Complete 260.22

2 Messer/Knives HS 59mm + 2 Abweiser/LimitersNr. 23-Komplett/Complete 260.23

2 Messer/Knives HS 59mm + 2 Abweiser/LimitersNr. 24-Komplett/Complete 260.24

2 Messer/Knives HS 59mm + 2 Abweiser/LimitersNr. 25-Komplett/Complete 260.25

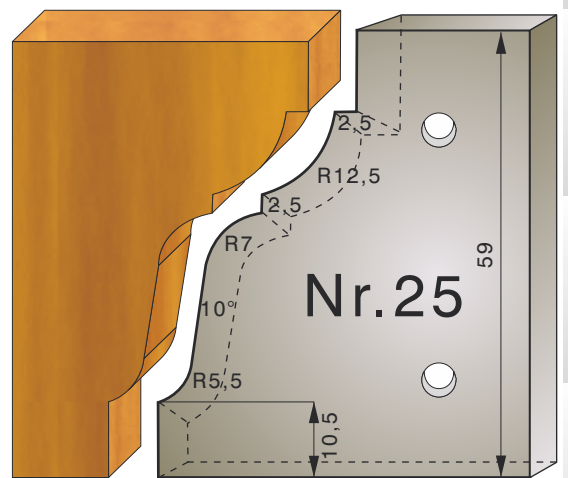
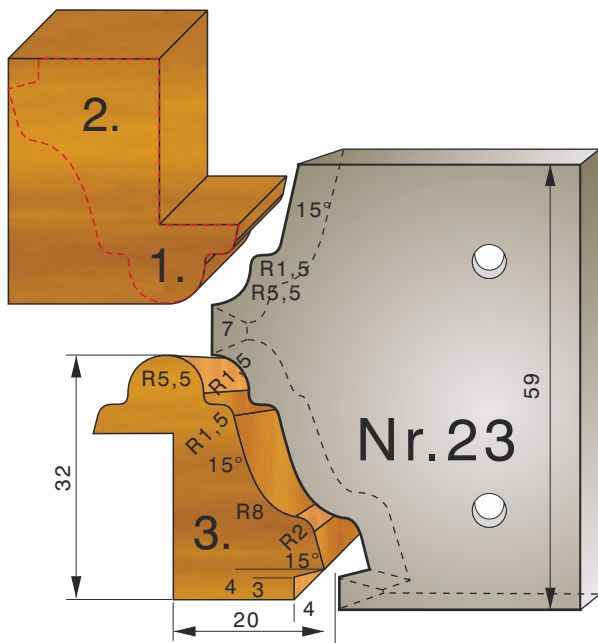
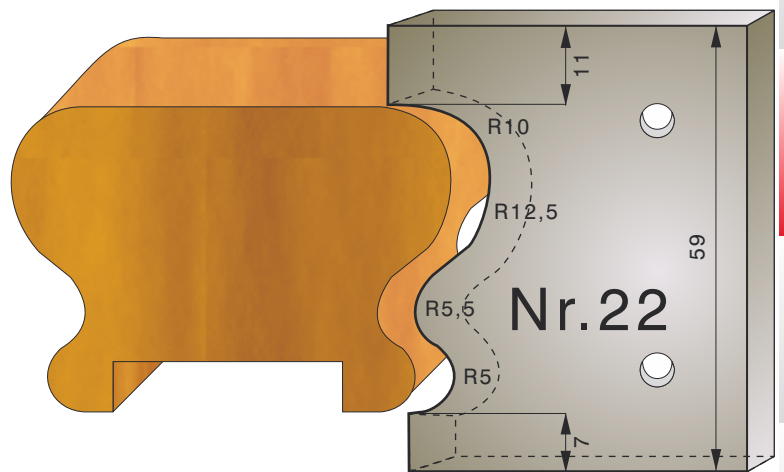
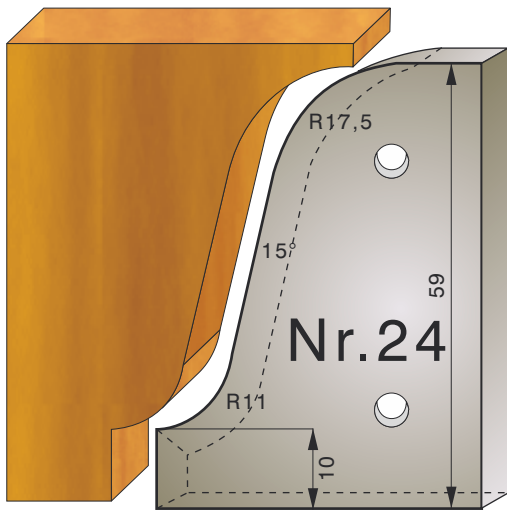

Standardmessersätze
Standard knife sets

Bestell-Nr.
Part-No.

2 Messer/Knives HS 64mm + 2 Abweiser/Limiters Nr. 26-Komplett/Complete 260.26

2 Messer/Knives HS 64mm + 2 Abweiser/Limiters Nr. 27-Komplett/Complete 260.27

2 Messer/Knives HS 59mm + 2 Abweiser/Limiters Nr. 28-Komplett/Complete 260.28

2 Messer/Knives HS 59mm + 2 Abweiser/Limiters Nr. 29-Komplett/Complete 260.29

